

# AKAI SERVICE MANUAL

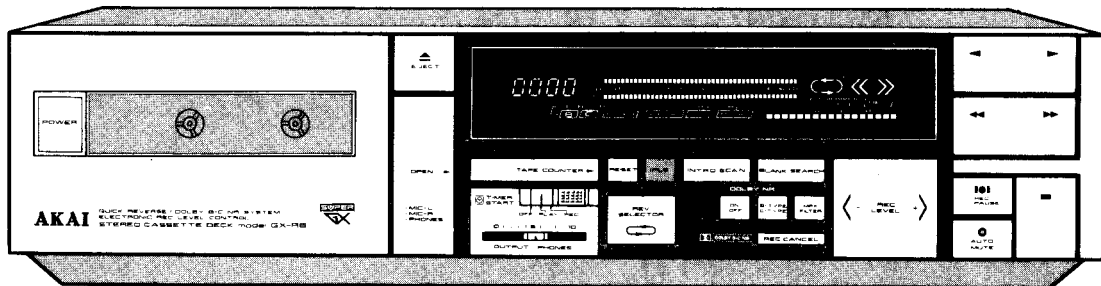
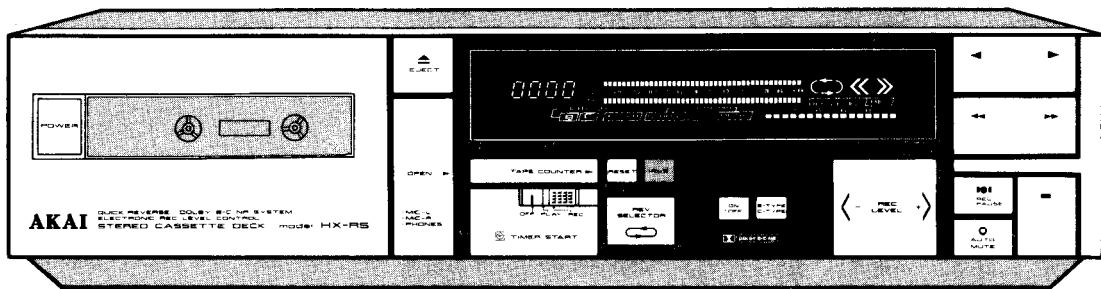

STEREO CASSETTE DECK

MODEL **HX-R5**

MODEL **GX-R6**

**ABBREVIATIONS FOR SERVICE MANUAL  
MODEL HX-R5/GX-R6**

ABBREVIATIONS	EXPLANATION
AC	Alternating Current
ADJ	ADJust
ALU	Arithmetic and Logic Unit
A-SW	Analogue SWitch
BSS	Blank Search System
DET	DETEctor
EQ	EQualizer
EXT	EXTernal
FF	Fast Forward
FLD	FLuorescent Display
FREQ	FREQuency
FWD	ForWarD
GND	GrouND
"H"	High (referring to voltage)
HLS	High Level Stage
INH	INHibit
IPLS	Instant Programme Locating System
LLS	Low Level Stage
MIC	MICrophone
NR	Noise Reduction
OSC	OSCillator
RL	ReLay
REC	RECord
REF	REFerence
REV	REVerse
REW	REWind
RWD	ReWinD
SEL	SELEct
SENS	SENSitivity
XTAL	CrysTAL

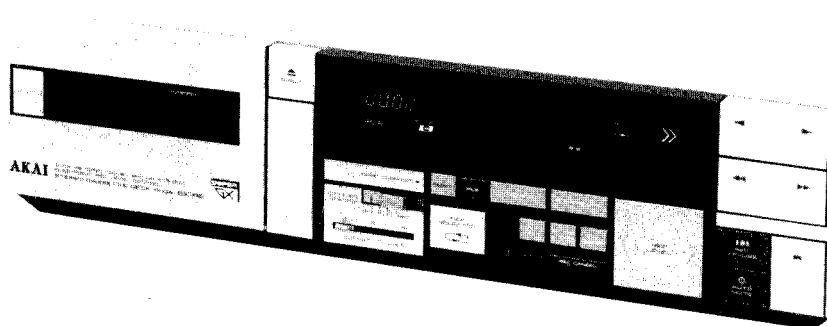
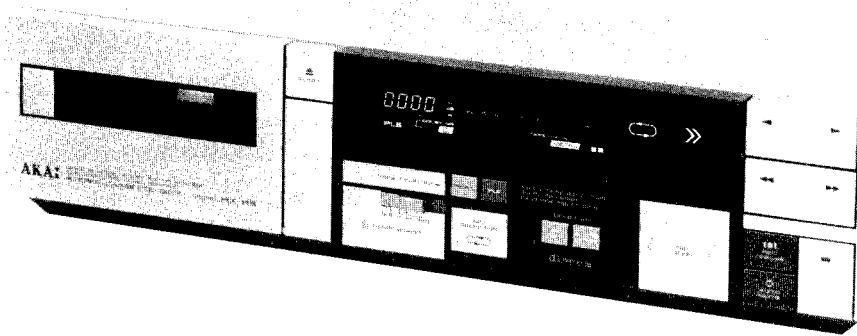

**STEREO CASSETTE DECK**

MODEL **HX-R5**

**STEREO CASSETTE DECK**

MODEL **GX-R6**

<b>SECTION 1</b>	<b>SERVICE MANUAL.....</b>	<b>3</b>
<b>SECTION 2</b>	<b>PARTS LIST.....</b>	<b>35</b>
<b>SECTION 3</b>	<b>SCHEMATIC DIAGRAM.....</b>	<b>53</b>

# SAFETY INSTRUCTIONS

## SAFETY CHECK AFTER SERVICING

Confirm the specified insulation resistance between power cord plug prongs and externally exposed parts of the set is greater than 10 Mohms, but for equipment with external antenna terminals (tuner, receiver, etc.) and is intended for **C** or **A**, specified insulation resistance should be more than 2.2 Mohms (ground terminals, microphone jacks, headphone jacks, line-in out jacks etc.).

## PRECAUTIONS DURING SERVICING

1. Parts identified by the  $\Delta$  symbol parts are critical for safety.  
Replace only with parts number specified.
2. In addition to safety, other parts and assemblies are specified for conformance with such regulations as those applying to spurious radiation. These must also be replaced only with specified replacements.  
Examples: RF converters, tuner units, antenna selector switches, RF cables, noise blocking capacitors, noise blocking filters, etc.
3. Use specified internal wiring. Note especially:
  - 1) Wires covered with PVC tubing
  - 2) Double insulated wires
  - 3) High voltage leads
4. Use specified insulating materials for hazardous live parts. Note especially:
  - 1) Insulation Tape
  - 2) PVC tubing
  - 3) Spacers (Insulating Barriers)
  - 4) Insulation sheets for transistors
  - 5) Plastic screws for fixing microswitch (especially in turntable)
5. When replacing AC primary side components (transformers, power cords, noise blocking capacitors, etc.), wrap ends of wires securely about the terminals before soldering.

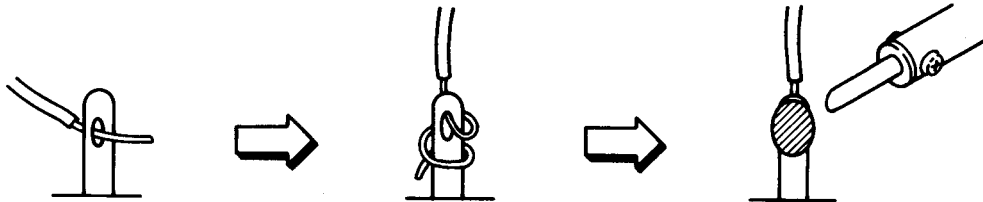

6. Observe that wires do not contact heat producing parts (heatsinks, oxide metal film resistors, fusible resistors, etc.).
7. Check that replaced wires do not contact sharp edged or pointed parts.
8. Also check areas surrounding repaired locations.
9. Use care that foreign objects (screws, solder droplets, etc.) do not remain inside the set.
10. Voltage Conversion
  - 1) Models for Japan, Canada, USA, Europe, UK and Australia are not equipped with this facility.  
Each machine is preset at the factory according to destination, but some machines can be set to 110V, 120V, 220V or 240V as required.  
If Voltage conversion on your machine is possible,
    - 1-1) Disconnect power cord.
    - 1-2) Turn the VOLTAGE SELECTOR located on the rear panel with a screwdriver until the correct voltage is indicated.

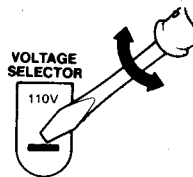

### 2) Cycle Conversion

Cycle conversion is not necessary since HX-R5 and GX-R6 uses DC motors.

---

SECTION 1

**SERVICE MANUAL**

TABLE OF CONTENTS

I.	SPECIFICATIONS .....	4
II.	DISMANTLING OF UNIT .....	6
III.	CONTROLS .....	7
IV.	PRINCIPAL PARTS LOCATION.....	8
V.	CIRCUIT OPERATION DESCRIPTION .....	9
	1. PRE-AMP BLOCK DIAGRAM .....	9
	2. SYSCON BLOCK DIAGRAM AND THE PERIPHERAL CIRCUIT.....	10
	3. ELECTRONIC VOLUME .....	11
VI.	MECHANICAL DESCRIPTION OF EACH MODEL .....	13
	1. DESCRIPTION OF THE MECHANISM DRIVEN BY CAM WHEELS (L) & (R) .....	13
VII.	MECHANICAL ADJUSTMENT .....	18
	1. PINCH ROLLER PRESSURE MEASUREMENTS .....	18
	2. WINDING TORQUE MEASUREMENT IN EACH MODE.....	18
	3. TAPE SPEED ADJUSTMENT .....	18
VIII.	HEAD ADJUSTMENT .....	19
	1. TAPE GUIDE ADJUSTMENT .....	20
	2. REC/PB HEAD AZIMUTH ADJUSTMENT .....	20
	3. HEAD HEIGHT ADJUSTMENT .....	20
	4. HEAD BLOCK PROJECTION ADJUSTMENT .....	20
IX.	ELECTRICAL ADJUSTMENT.....	21
	1. SYSCON P.C BOARD ADJUSTMENT .....	21
	2. PRE-AMP P.C BOARD ADJUSTMENT .....	22
X.	DC RESISTANCE OF HEAD.....	24
XI.	CLASSIFICATION OF VARIOUS P.C BOARDS .....	24
	1. P.C BOARD TITLES AND IDENTIFICATION NUMBERS.....	24
	2. COMPOSITION OF VARIOUS P.C BOARDS .....	25

# I. SPECIFICATIONS

## 1-1. MODEL HX-R5

Track system	4 Track 2 Channel stereo system
Tape	Philips type cassette
Heads	Erase Head × 1 High Density for REC/PB × 1
Motors	Electronically speed controlled DC motor for capstan drive × 1 DC motor for cam drive × 1
Wow & Flutter	0.12% (DIN) 0.04% (W. RMS) ±0.07% W. PEAK (EIAJ)
Frequency Response	NORMAL: 20 to 15,000 Hz ± 3 dB (-20 VU) CrO <sub>2</sub> : 20 to 16,000 Hz ± 3 dB (-20 VU) METAL: 20 to 17,000 Hz ± 3 dB (-20 VU)
S/N	58 dB 55 dB (EIAJ) DOLBY B ON: Improves up to 5 dB at 1 kHz 10 dB above 5 kHz DOLBY C ON: Improves up to 15 dB at 500 Hz 20 dB at 1 kHz to 10 kHz
Distortion	0.7% (METAL)
Input	LINE: 70 mV/47 kohms MIC: 2.5 mV/5 kohms
Output	LINE: 410 mV/1 kohms PHONE: 1.3 mW/8 ohms
Power Requirements	100V, 50/60 Hz for Japan 120V, 60 Hz for USA and Canada 220V, 50 Hz for Europe except UK 240V, 50Hz for UK and Australia 110V/120V/220V/240V, 50/60 Hz switchable for other countries
Power Consumption	JPN: 18W CSA, AAL: 18W UT: 18W
Dimensions	440 (W) × 105 (H) × 288 (D) mm (17.3 × 4.1 × 11.3 inches)
Weight	4.7 kg (10.3 lbs)

\* For improvement purposes, specifications and design are subject to change without notice.

\* Noise reduction manufactured under license from Dolby Laboratories Licensing Corporation. "Dolby" and the Double-D symbol are trade marks of Dolby Laboratories Licensing Corporation.

## 1-2. MODEL GX-R6

Track system	4 Track 2 Channel stereo system
Tape	Philips type cassette
Heads	Erase Head × 1 Twin Field super GX head for REC/PB × 1
Motors	Electronically speed controlled DC motor for capstan drive × 1 DC motor for cam drive × 1
Wow & Flutter	0.12% (DIN) 0.04% (W. RMS) ±0.07% W. PEAK (EIAJ)
Frequency Response	NORMAL: 20 to 17,000 Hz ± 3 dB (-20VU) CrO <sub>2</sub> : 20 to 18,000 Hz ± 3 dB (-20VU) METAL: 20 to 19,000 Hz ± 3 dB (-20VU)
S/N	58 dB 55 dB (EIAJ) DOLBY B ON: Improves up to 5 dB at 1 kHz 10 dB above 5 kHz DOLBY C ON: Improves up to 15 dB at 500 Hz 20 dB at 1 kHz to 10 kHz
Distortion	0.7% (METAL)
Input	LINE: 70 mV/47 kohms MIC: 2.5 mV/5 kohms
Output	LINE: 410 mV/1 kohms PHONE: 1.3 mW/8 ohms
Power Requirements	100V, 50/60 Hz for Japan 120V, 60 Hz for USA and Canada 220V, 50 Hz for Europe except UK 240V, 50Hz for UK and Australia 110V/120V/220V/240V, 50/60 Hz switchable for other countries
Power Consumption	JPN: 16W CSA, AAL: 17W UT: 17W
Dimensions	440 (W) × 105 (H) × 288 (D) mm (17.3 × 4.1 × 11.3 inches)
Weight	4.7 kg (10.3 lbs)

\* For improvement purposes, specifications and design are subject to change without notice.

\* Noise reduction manufactured under license from Dolby Laboratories Licensing Corporation. "Dolby" and the Double-D symbol are trade marks of Dolby Laboratories Licensing Corporation.

## II. DISMANTLING OF UNIT

In case of trouble, etc. necessitating dismantling, please dismantle in the order shown in the photographs. Reassemble in reverse order.

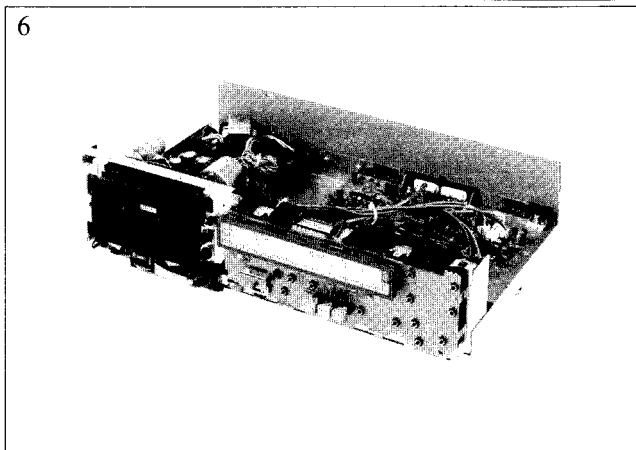
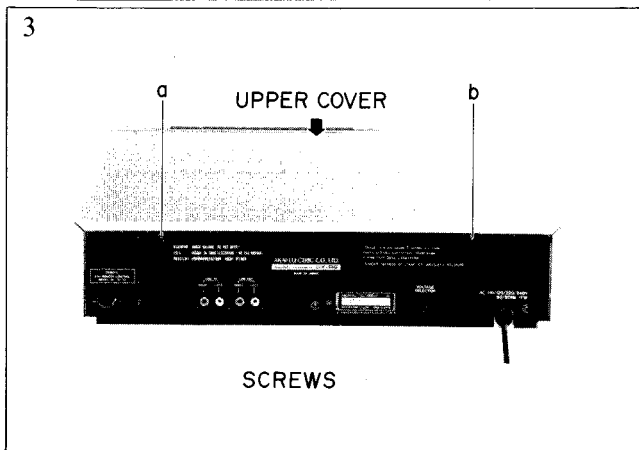
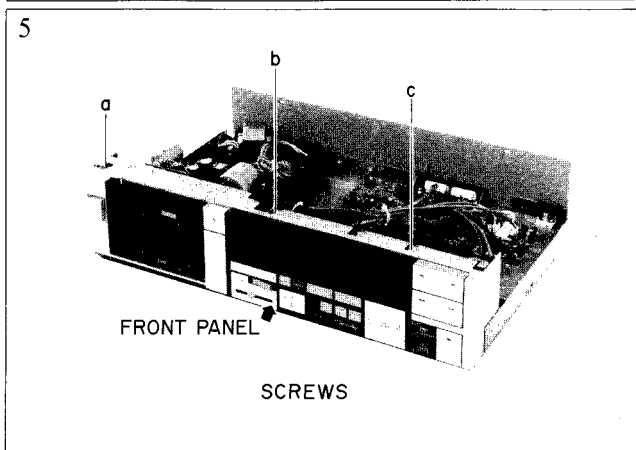
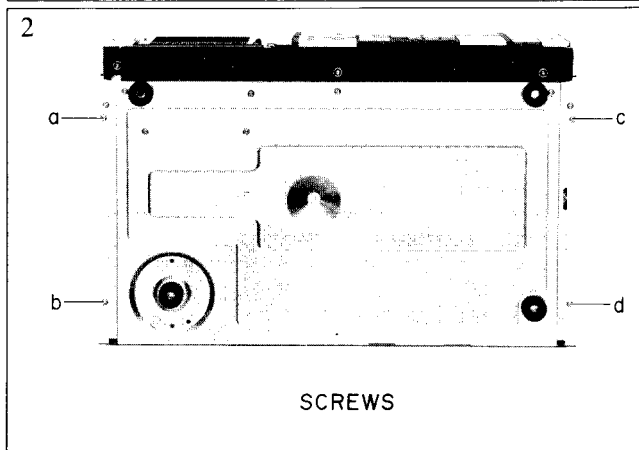
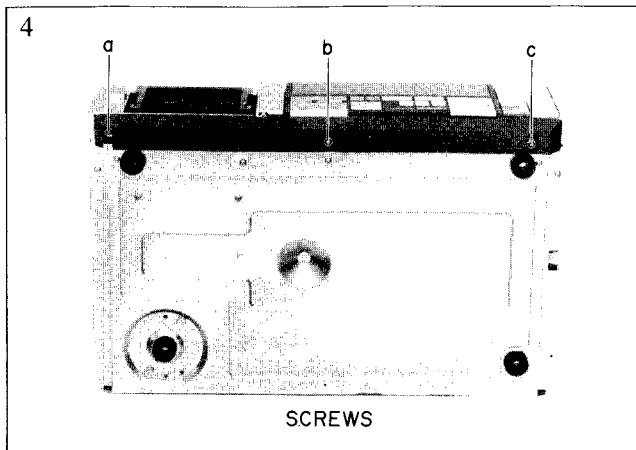
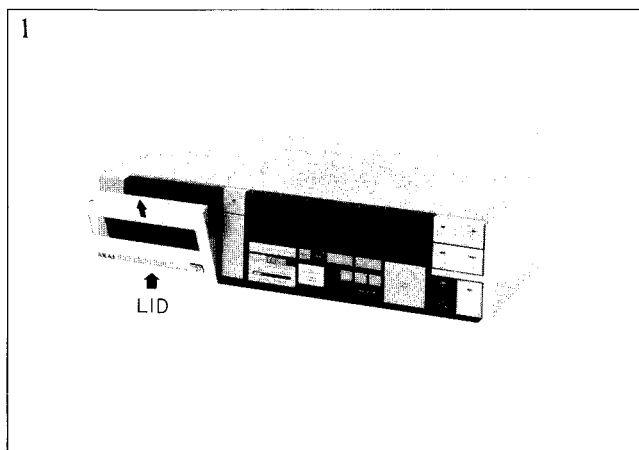



### III. CONTROLS

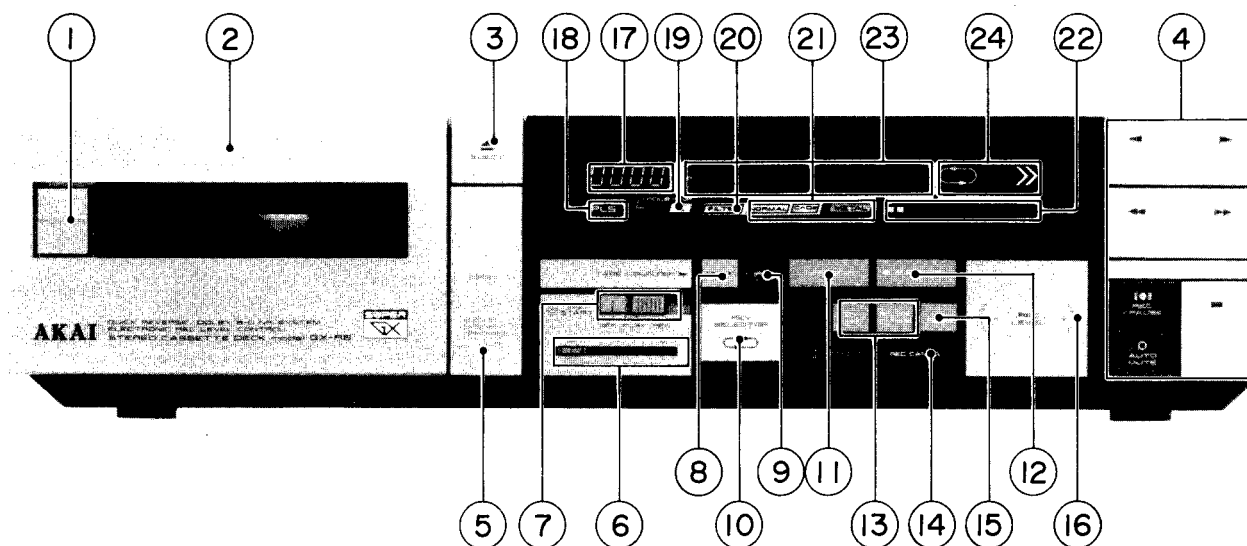

Fig. 3-1 Front View

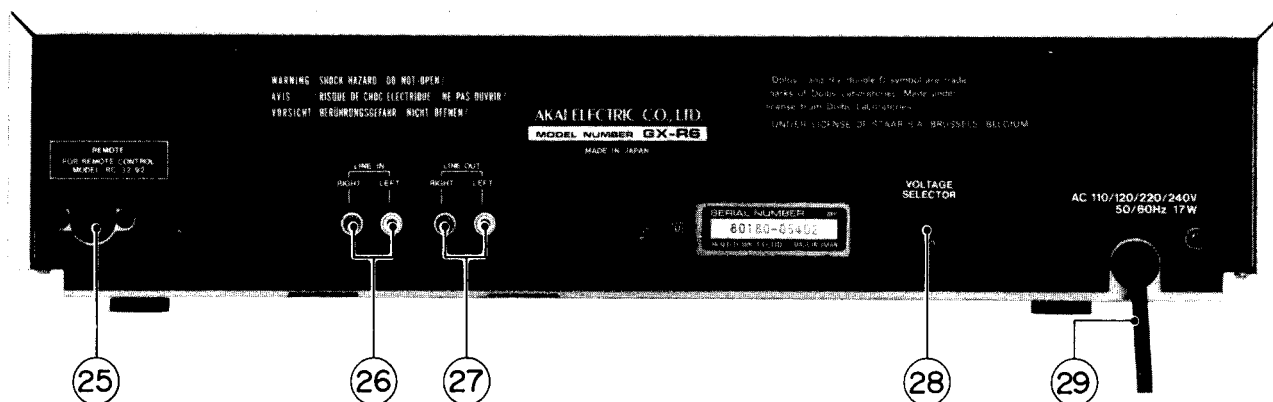

Fig. 3-2 Rear View

- |  |   |
|--|---|
| <ol style="list-style-type: none"> <li>1. POWER SWITCH</li> <li>2. CASSETTE HOLDER</li> <li>3. EJECT BUTTON</li> <li>4. OPERATION BUTTONS</li> <li>5. CONTAINS JACKS FOR MIC L/R AND HEADPHONE</li> <li>6. OUTPUT/PHONES CONTROL (GX-R6 ONLY)</li> <li>7. TIMER START SELECTOR</li> <li>8. RESET BUTTON FOR DIGITAL COUNTER</li> <li>9. IPLS BUTTON</li> <li>10. REV SELECTOR</li> <li>11. INTRO SCAN BUTTON (GX-R6 ONLY)</li> <li>12. BLANK SEARCH BUTTON (GX-R6 ONLY)</li> <li>13. DOLBY NR SWITCH AND SELECTOR</li> <li>14. REC CANCEL BUTTON (GX-R6 ONLY)</li> <li>15. MPX FILTER SWITCH (GX-R6 ONLY)</li> </ol> | <ol style="list-style-type: none"> <li>16. REC LEVEL CONTROL</li> <li>17. DIGITAL COUNTER</li> <li>18. IPLS INDICATOR</li> <li>19. DOLBY B/C INDICATORS</li> <li>20. MPX FILTER INDICATOR (GX-R6 ONLY)</li> <li>21. TAPE (NORMAL, CrO<sub>2</sub>, METAL) INDICATORS</li> <li>22. REC LEVEL POSITION INDICATOR</li> <li>23. REC/P.B LEVEL INDICATORS</li> <li>24. REV SELECTOR AND DIRECTION INDICATORS</li> <li>25. REMOTE CONTROL JACK</li> <li>26. LINE IN (L/R) JACKS</li> <li>27. LINE OUT (L/R) JACKS</li> <li>28. VOLTAGE SELECTOR (<u>U</u>) model only</li> <li>29. AC POWER CORD</li> </ol> |
|--|---|

# IV. PRINCIPAL PARTS LOCATION

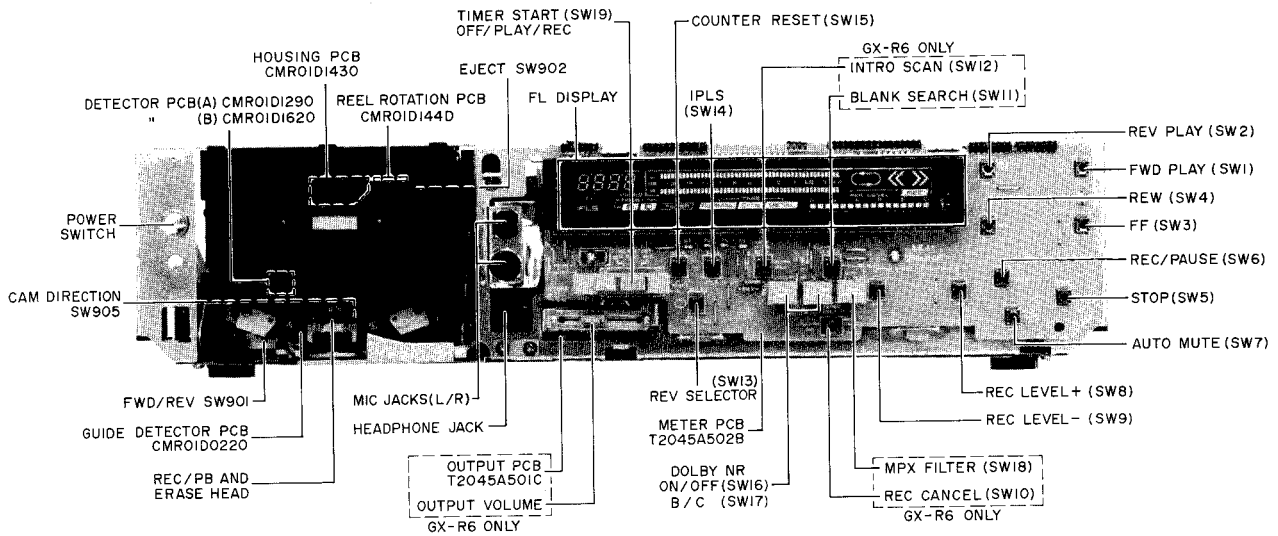

Fig. 4-1 Front View

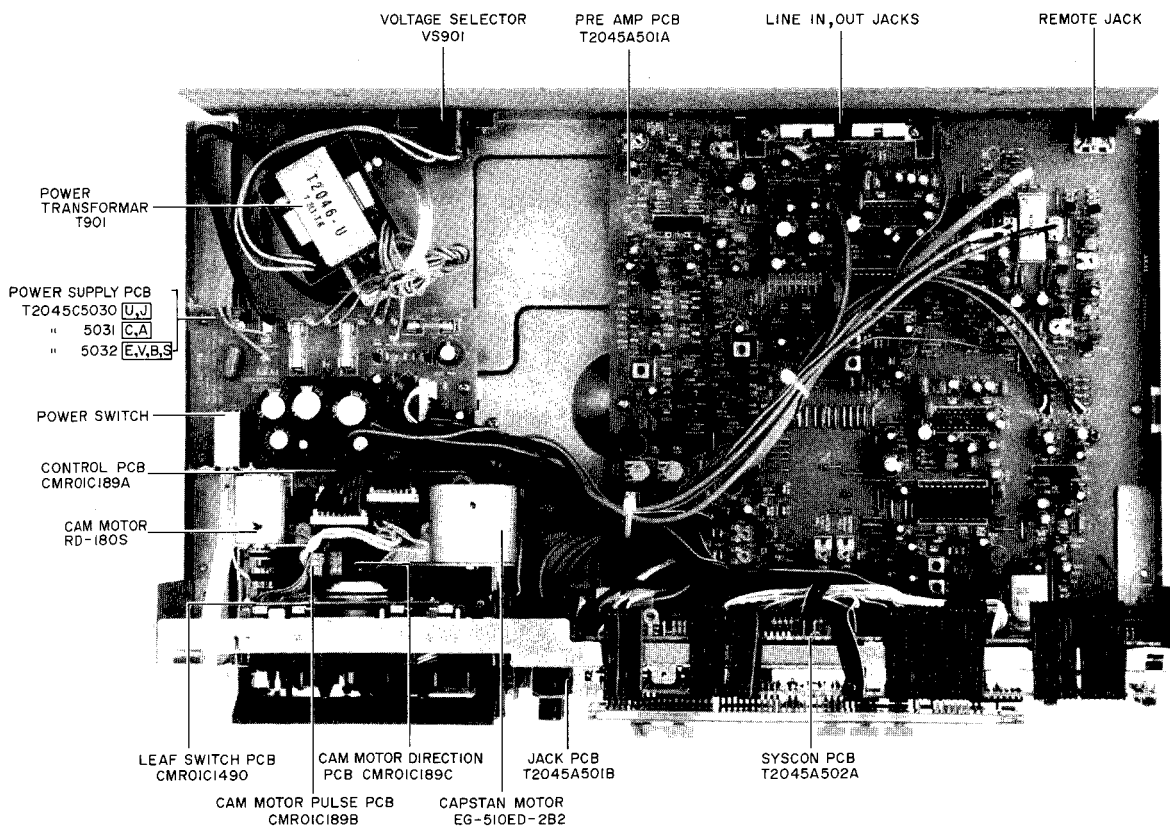

Fig. 4-2 Top View

# V. CIRCUIT OPERATION DESCRIPTION

## 5-1. PRE-AMP BLOCK DIAGRAM

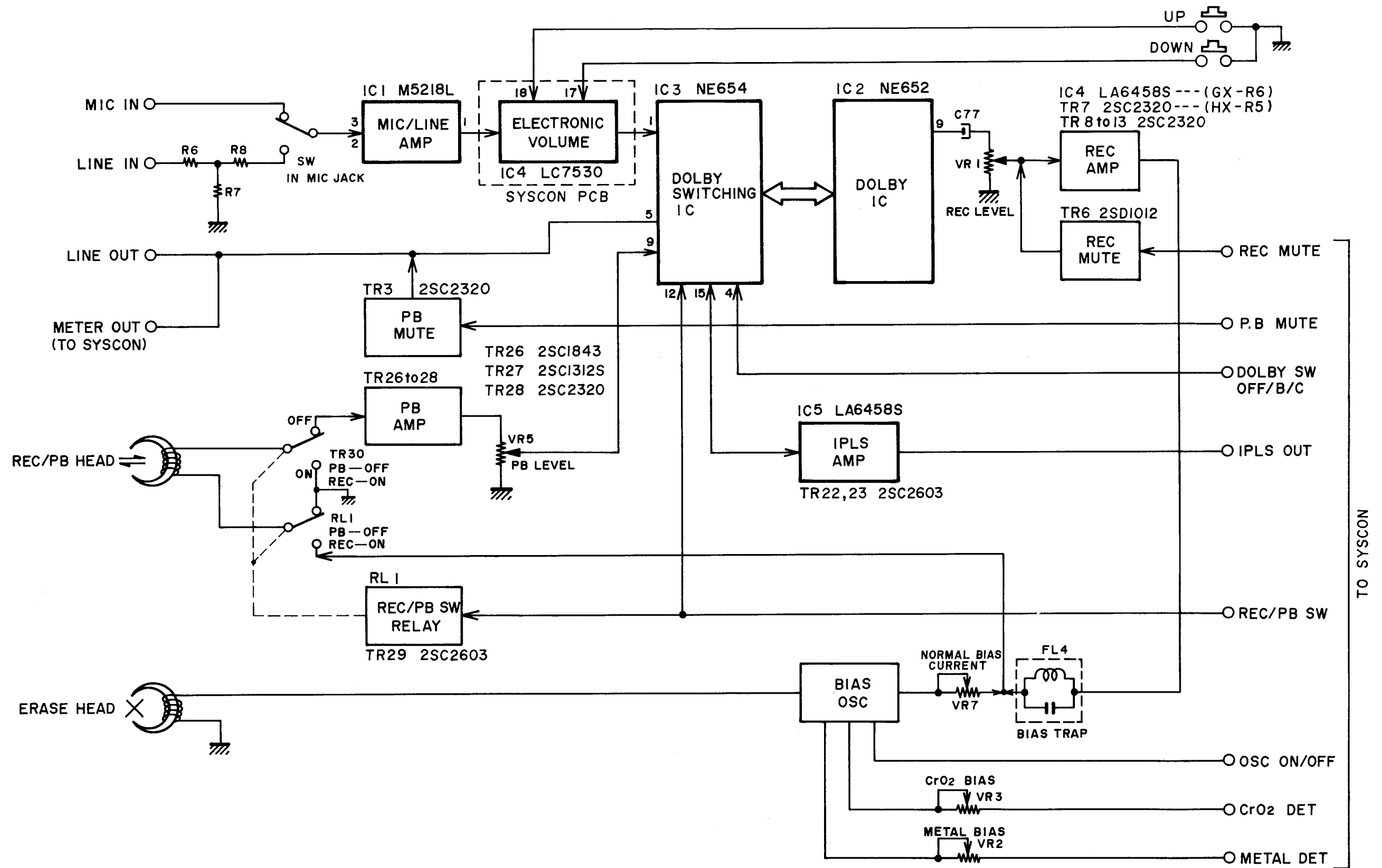

Fig. 5-1 Block Diagram of Pre-Amp P.C Board

5-2. SYSCON BLOCK DIAGRAM AND THE PERIPHERAL CIRCUIT

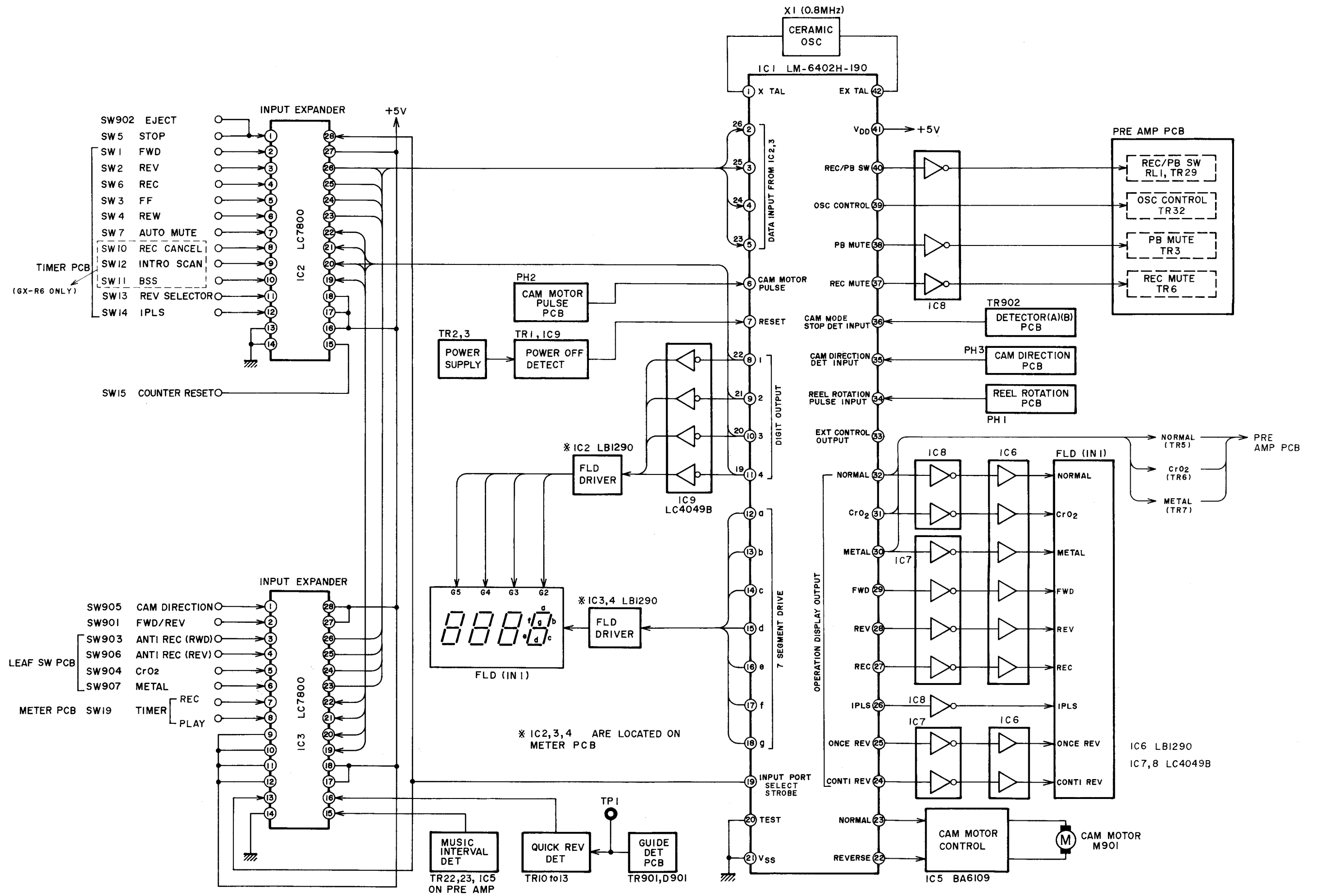

Fig. 5-2 Block Diagram of Syscon P.C Board

### 5-3. ELECTRONIC VOLUME

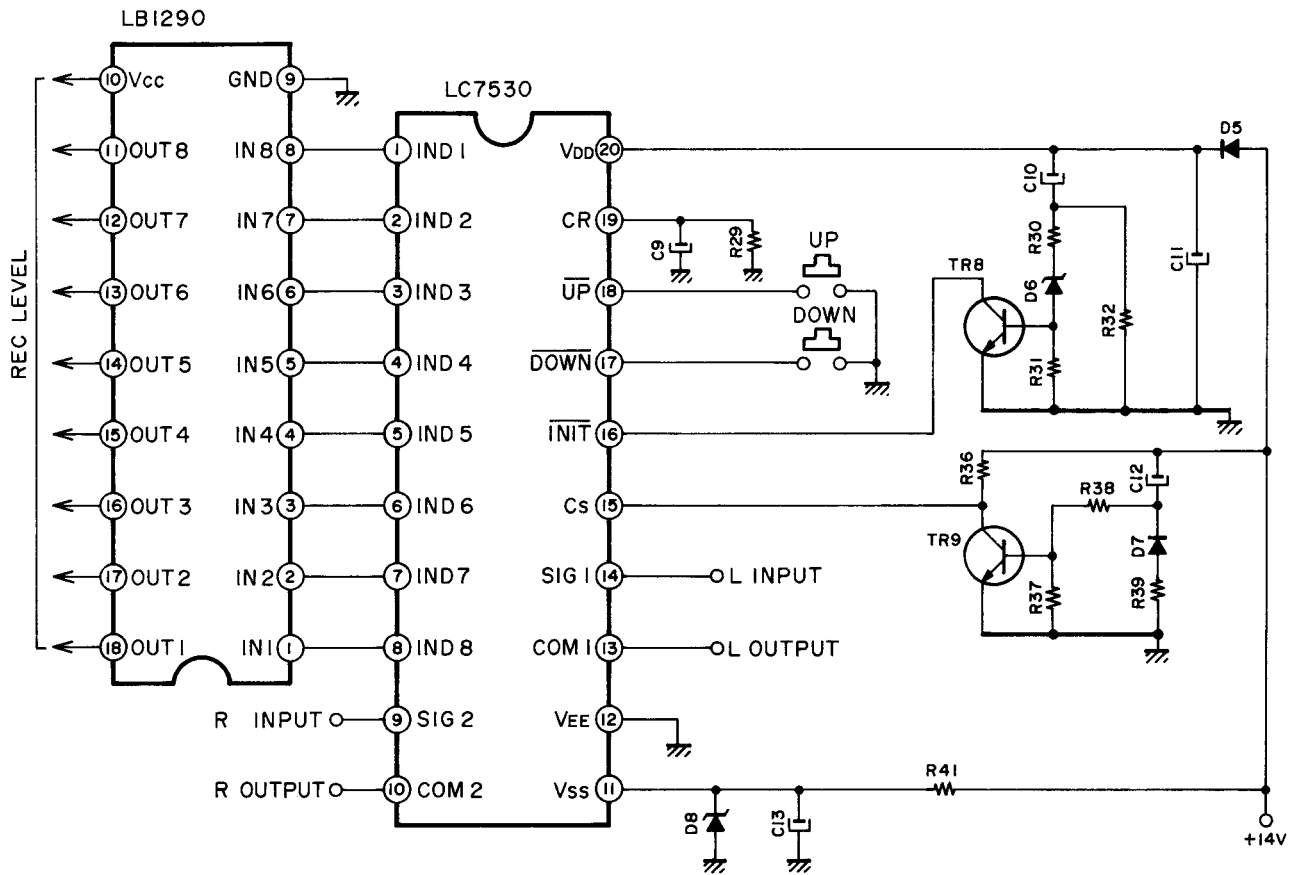

Fig. 5-3

Model HX-R5, GX-R6 employs Electronic Volume instead of Mechanical REC Volume, and uses an IC (LC7530) for both channels.

Pin No.	Symbol	Description																																																																																																																																																																	
1 2 8	IND1  IND8	REC Level Indicator Drive Terminal																																																																																																																																																																	
		<table border="1"> <thead> <tr> <th rowspan="2">Attenuation Step</th> <th colspan="8">IND</th> </tr> <tr> <th>8</th> <th>7</th> <th>6</th> <th>5</th> <th>4</th> <th>3</th> <th>2</th> <th>1</th> </tr> </thead> <tbody> <tr><td>0</td><td></td><td></td><td></td><td></td><td></td><td></td><td></td><td></td></tr> <tr><td>1</td><td></td><td></td><td></td><td></td><td></td><td></td><td></td><td>H</td></tr> <tr><td>2</td><td></td><td></td><td></td><td></td><td></td><td></td><td>H</td><td>H</td></tr> <tr><td>3</td><td></td><td></td><td></td><td></td><td></td><td></td><td>H</td><td></td></tr> <tr><td>4</td><td></td><td></td><td></td><td></td><td></td><td>H</td><td>H</td><td></td></tr> <tr><td>5</td><td></td><td></td><td></td><td></td><td></td><td>H</td><td></td><td></td></tr> <tr><td>6</td><td></td><td></td><td></td><td></td><td>H</td><td>H</td><td></td><td></td></tr> <tr><td>7</td><td></td><td></td><td></td><td></td><td>H</td><td></td><td></td><td></td></tr> <tr><td>8</td><td></td><td></td><td></td><td>H</td><td>H</td><td></td><td></td><td></td></tr> <tr><td>9</td><td></td><td></td><td></td><td>H</td><td></td><td></td><td></td><td></td></tr> <tr><td>10</td><td></td><td></td><td>H</td><td>H</td><td></td><td></td><td></td><td></td></tr> <tr><td>11</td><td></td><td></td><td>H</td><td></td><td></td><td></td><td></td><td></td></tr> <tr><td>12</td><td></td><td>H</td><td>H</td><td></td><td></td><td></td><td></td><td></td></tr> <tr><td>13</td><td></td><td>H</td><td></td><td></td><td></td><td></td><td></td><td></td></tr> <tr><td>14</td><td>H</td><td>H</td><td></td><td></td><td></td><td></td><td></td><td></td></tr> <tr><td>15</td><td>H</td><td></td><td></td><td></td><td></td><td></td><td></td><td></td></tr> </tbody> </table>	Attenuation Step	IND								8	7	6	5	4	3	2	1	0									1								H	2							H	H	3							H		4						H	H		5						H			6					H	H			7					H				8				H	H				9				H					10			H	H					11			H						12		H	H						13		H							14	H	H							15	H							
Attenuation Step	IND																																																																																																																																																																		
	8	7	6	5	4	3	2	1																																																																																																																																																											
0																																																																																																																																																																			
1								H																																																																																																																																																											
2							H	H																																																																																																																																																											
3							H																																																																																																																																																												
4						H	H																																																																																																																																																												
5						H																																																																																																																																																													
6					H	H																																																																																																																																																													
7					H																																																																																																																																																														
8				H	H																																																																																																																																																														
9				H																																																																																																																																																															
10			H	H																																																																																																																																																															
11			H																																																																																																																																																																
12		H	H																																																																																																																																																																
13		H																																																																																																																																																																	
14	H	H																																																																																																																																																																	
15	H																																																																																																																																																																		
9 10 13 14	SIG2 COM2 COM1 SIG1	RCH Signal Input Terminal. RCH Signal Output Terminal. LCH Signal Output Terminal. LCH Signal Input Terminal.																																																																																																																																																																	
		<table border="1"> <thead> <tr> <th>Attenuation Step</th> <th>Attenuation (dB)</th> </tr> </thead> <tbody> <tr><td>0</td><td>0</td></tr> <tr><td>1</td><td>-1.0</td></tr> <tr><td>2</td><td>-2.0</td></tr> <tr><td>3</td><td>-3.4</td></tr> <tr><td>4</td><td>-5.1</td></tr> <tr><td>5</td><td>-7.1</td></tr> <tr><td>6</td><td>-9.3</td></tr> <tr><td>7</td><td>-11.7</td></tr> <tr><td>8</td><td>-14.1</td></tr> <tr><td>9</td><td>-16.5</td></tr> <tr><td>10</td><td>-18.8</td></tr> <tr><td>11</td><td>-21.1</td></tr> <tr><td>12</td><td>-24.5</td></tr> <tr><td>13</td><td>-28.8</td></tr> <tr><td>14</td><td>-34.0</td></tr> <tr><td>15</td><td>-80.0</td></tr> </tbody> </table>	Attenuation Step	Attenuation (dB)	0	0	1	-1.0	2	-2.0	3	-3.4	4	-5.1	5	-7.1	6	-9.3	7	-11.7	8	-14.1	9	-16.5	10	-18.8	11	-21.1	12	-24.5	13	-28.8	14	-34.0	15	-80.0																																																																																																																															
Attenuation Step	Attenuation (dB)																																																																																																																																																																		
0	0																																																																																																																																																																		
1	-1.0																																																																																																																																																																		
2	-2.0																																																																																																																																																																		
3	-3.4																																																																																																																																																																		
4	-5.1																																																																																																																																																																		
5	-7.1																																																																																																																																																																		
6	-9.3																																																																																																																																																																		
7	-11.7																																																																																																																																																																		
8	-14.1																																																																																																																																																																		
9	-16.5																																																																																																																																																																		
10	-18.8																																																																																																																																																																		
11	-21.1																																																																																																																																																																		
12	-24.5																																																																																																																																																																		
13	-28.8																																																																																																																																																																		
14	-34.0																																																																																																																																																																		
15	-80.0																																																																																																																																																																		
<p>This attenuator shown above is made up of diffused resistors R (50 kohms) and analogue switches (SW0 ~ 15), and it attenuates 0 dB to 80 dB in 16 steps (step 0 to 15).</p>																																																																																																																																																																			
11	VSS	Center Bias Terminal. Connected to the ground of signal line.																																																																																																																																																																	
12	VEE	Connected to ground.																																																																																																																																																																	
15	CS	Back-up Control Terminal. Back-up mode at "L".																																																																																																																																																																	
16	$\overline{\text{INT}}$	Attenuator (step 9) Set Up Terminal, active at "L".																																																																																																																																																																	
17	$\overline{\text{DOWN}}$	Attenuator Control Signal Input Terminal. (Increases attenuation)																																																																																																																																																																	
18	$\overline{\text{UP}}$	Attenuator Control Signal Input Terminal. (Decreases attenuation)																																																																																																																																																																	
<p><math>\overline{\text{DOWN}}</math> → Becoming "L" level at this terminal activates the internal oscillator, and Attenuation is increased one step each time at the rising edge of oscillation wave. Keeping this terminal at "L" level continues attenuation rise until the attenuation rise and oscillation stop at the sixteenth step. (Attenuation of 80 dB)</p> <p><math>\overline{\text{UP}}</math> → Attenuation decreases in the same manner as above.</p>																																																																																																																																																																			
19	CR	Capacitor and Resistor Terminal for Internal Clock Oscillator.																																																																																																																																																																	
20	VDD	Power Supply Terminal (+20V).																																																																																																																																																																	

Chart 1

# VI. MECHANICAL DESCRIPTION PART FOR EACH MODE

## 6-1. DESCRIPTION OF THE MECHANISM DRIVEN BY CAM WHEELS (L) & (R)

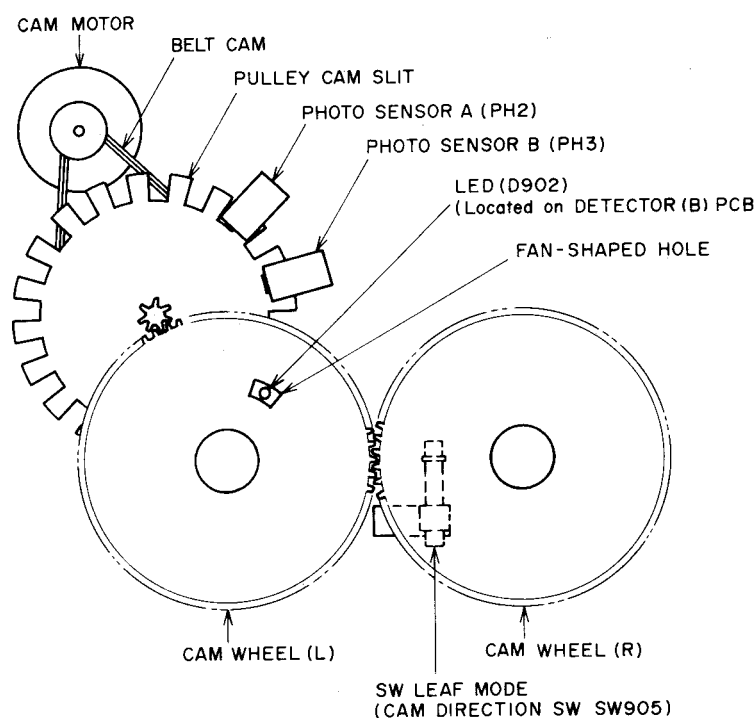

Fig. 6-1 Cam Wheels (L) & (R) Drive Mechanism (Front View)

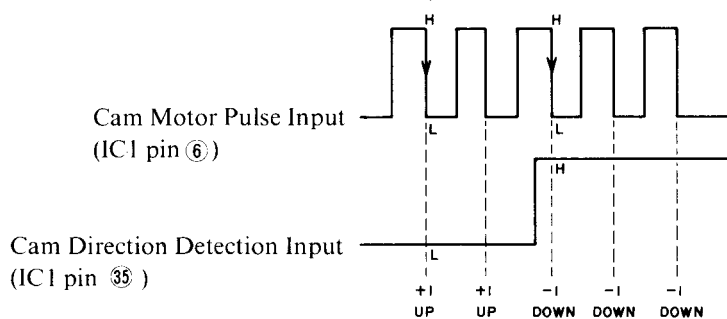

Fig. 6-2

**6-1-1.** The sequence of this transmission is as follows.  
(Refer to Fig. 6-1)

CAM MOTOR → BELT CAM → PULLEY CAM SLIT  
→ CAM WHEEL (L) → CAM WHEEL (R)

**6-1-2.** CAM MOTOR is driven by IC5 (BA6109) on SYSCON PCB and this IC5 is controlled by the various control signals from various detectors and switches through the action of MI-COM IC1 (LM6402H-190).

**6-1-3.** PULLEY CAM SLIT is driven by BELT CAM and drives CAM WHEEL (L), and the slits on PULLEY CAM SLIT are used for the detection of CAM MOTOR PULSE and CAM DIRECTION.

**6-1-4.** CAM WHEELS (L) (R) contain grooves to shift 8 mechanical parts shown in Figs. 6-5 & 6-6, which execute all the operations such as;

- 1) Shifting Head block up and down.
- 2) Shifting Pinch Rollers up and down.
- 3) Rotation of Reel Tables.
- 4) Rotation of Head (for FWD & REV modes)

**6-1-5.** SW LEAF MODE is used for the detection of the current CAM WHEEL position. It is "ON" during REV/FF modes and "OFF" during FWD/REW modes.

**6-1-6.** DETECTORS A, B are used for the detection of STOP mode. TR902 is "ON" during STOP mode.

**6-1-7.** PHOTO-SENSOR A (PH2) is used for the detection of CAM MOTOR PULSES, and together with PHOTO-SENSOR B, its count sets up the position of the CAM WHEELS.

**6-1-8.** PHOTO SENSOR B (PH3) is used for the detection of CAM direction. That part of the CAM MOTOR PULSE in which the pulse changes from "H" to "L" is used for counting up (+) and down (-) as indicated in Fig. 6-2 to set up CAM WHEELS (L) & (R).

6-1-9. Mechanical Operations in each mode

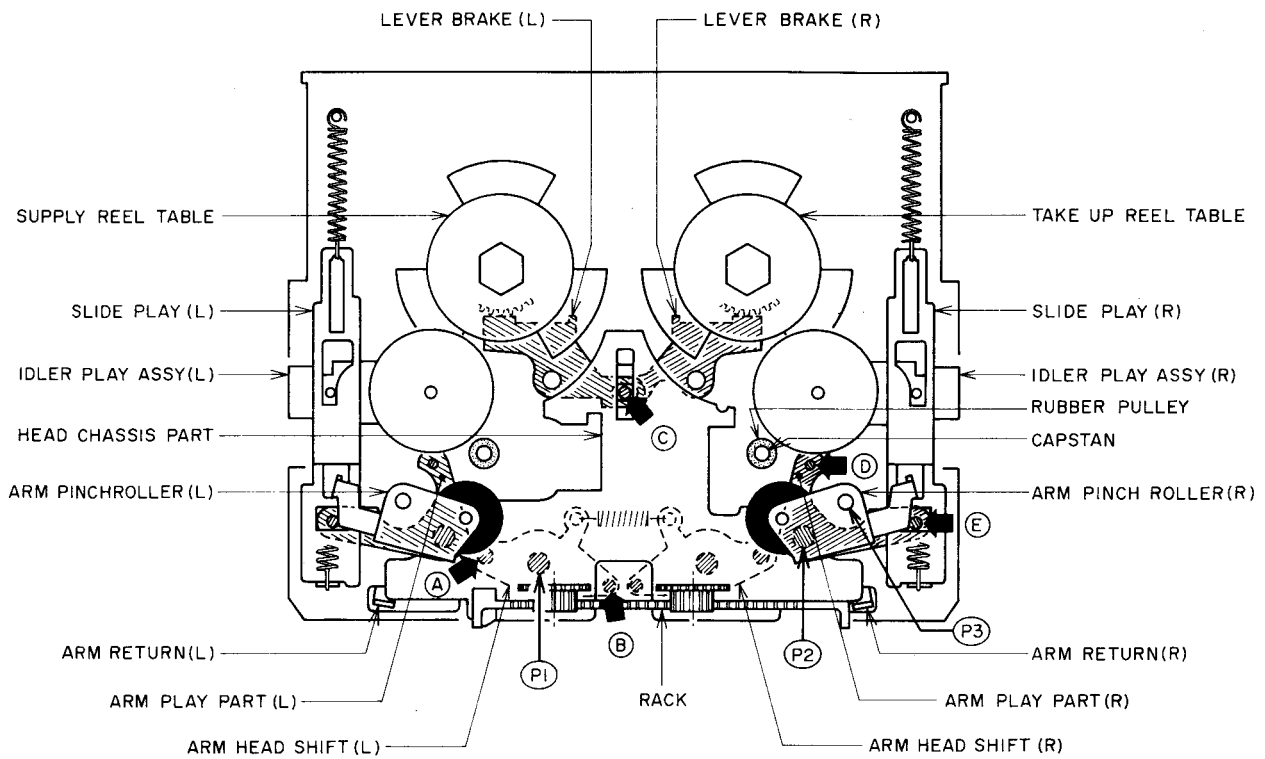

Fig. 6-3 The Mechanism for FWD/REV Mode

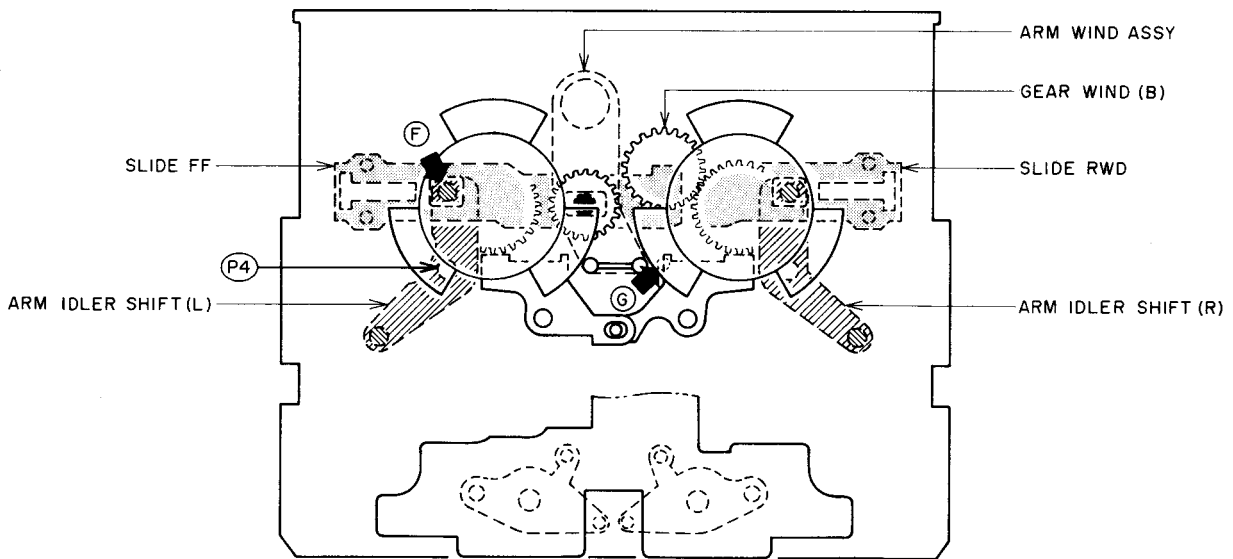

Fig. 6-4 The Mechanism for FF/RWD (includes IPLS & Intro Scan)



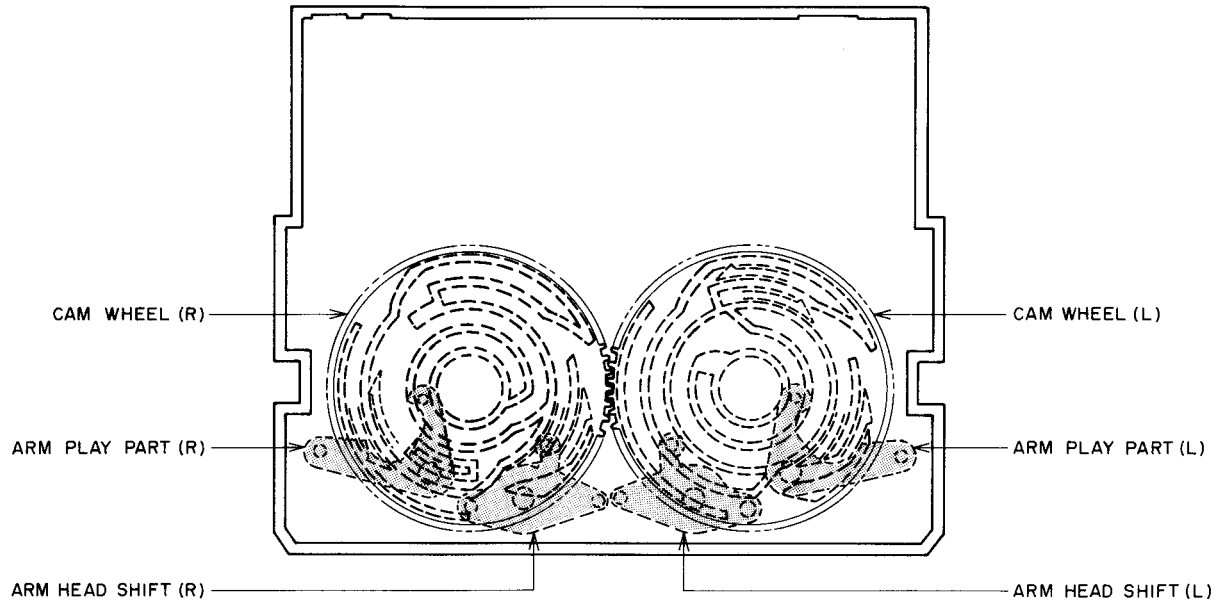

Fig. 6-5 The Location of Arm Head Shift & Arm Play (Inside View)

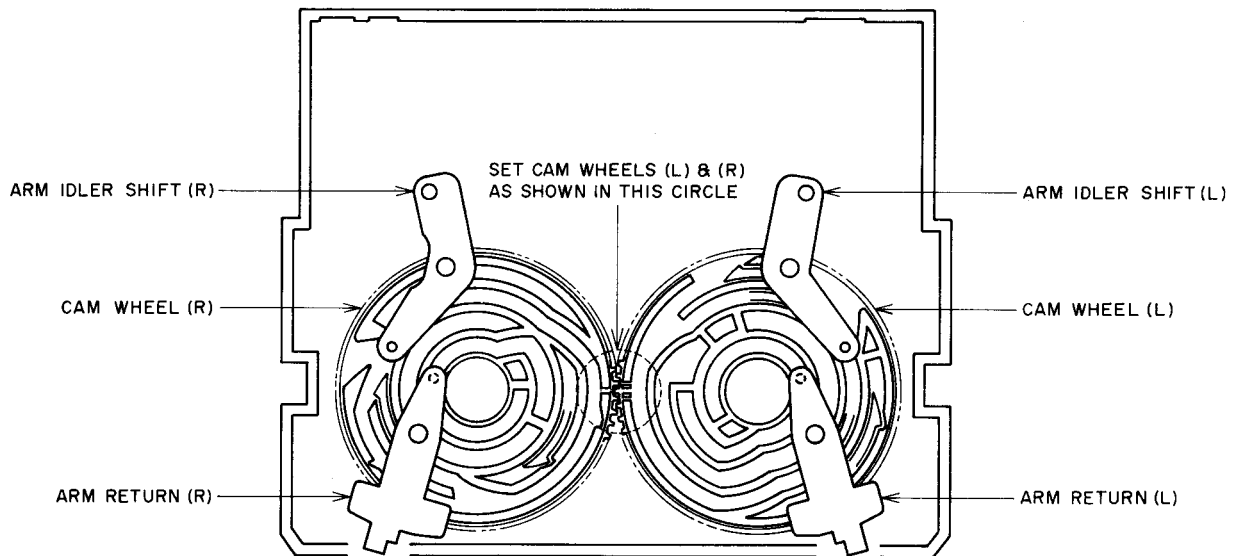

Fig. 6-6 The Location of Arm Idler Shift & Arm Return (Inside View)

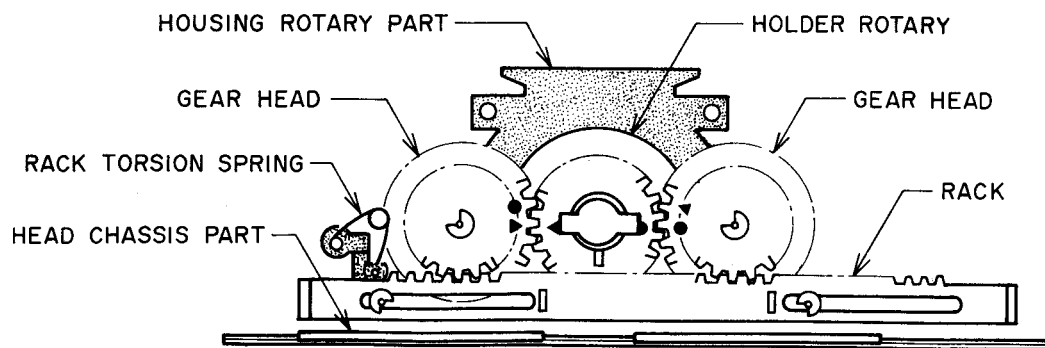

Fig. 6-7 The Bottom View of Rotary Head Mechanism (FWD Mode)

1) FWD mode (Refer to Fig. 6-3)

Cam Wheels (L) & (R) turn clockwise (L) and counter-clockwise (R) for +91 counts in each direction, and put on the brake for 20m sec. (All the other modes end with the brake operating for 20m sec as well.)

The mechanical operations in the meantime are as follows.

- a) Arm Return (L) moves to the right and pushes Rack in the same direction so that the Rotary head turns into the FWD position.
- b) Arm Head Shift (L) turns on its pivot (P<sub>1</sub>) so Part (A) moves downwards and Part (B) moves upwards. (Part (B))
  - pushes Head Chassis up to the position for play mode.
  - pushes Lever Brake (Part (C)) up and release the brake.
- c) Arm Play (R) turns on its pivot (P<sub>2</sub>) so Part (D) moves to the right, and Part (E) moves downwards and pushes Slide Play (R) down so that Idler Play Assy (R) moves to the left and transmits the rotation of the Capstan to the Take-up Reel Table.

At the same time, Arm Pinch Roller (R) turns clockwise on its Pivot (P<sub>3</sub>) and Pinch Roller (R) comes up for Play mode.

2) REV mode (Refer to Fig. 6-3)

Cam Wheels (L) & (R) turn counter-clockwise (L) and clockwise (R) for the same counts as FWD mode.

The mechanical operations in REV mode can be obtained from the description of FWD mode in item 1) by interchanging left (L) and right (R).

3) FF mode (Refer to Fig. 6-4)

- a) Cam Wheels (L) & (R) turn counter-clockwise (L) and clockwise (R) for 43 counts and turn the other way (clockwise (L), counter-clockwise (R)) until the count is reduced to 25.

- b) In FF & RWD modes, only Arm Idler Shift (L), (R) are involved.

Arm Idler Shift (L) turns on its pivot (P<sub>4</sub>) so Part (F) moves to the right which pushes the Slide FF to the right

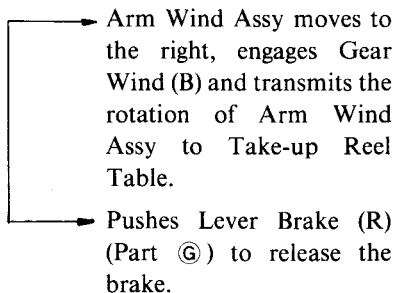

4) RWD mode (Refer to Fig. 6-4)

- a) Cam Wheels (L) & (R) turn clockwise (L) and counter-clockwise (R) for the same counts as FF mode.
- b) The mechanical operations in RWD mode can be obtained from the description of the FF mode in item 1) by interchanging left (L) and right (R).

5) FF Search (IPLS, Intro Scan)

- a) Cam Wheels turn in the same directions as in FF mode for 51 counts and for the reduction of 25 counts.
- b) The mechanical operations in this mode are the same as in FF mode, except that the Arm Head Shift (L) pushes up the Chassis Head Part which raises the Head Block to the FF Search mode position.

6) RWD Search (IPLS, Intro Scan)

- a) Cam Wheels turn in the same directions as in RWD mode for the same counts as in FF search mode.
- b) The mechanical operations in this mode are the same as in REW mode, except that the Arm Head Shift (R) pushes up the Chassis Head Part which raises the Head Block to the RWD Search mode position.

**6-1-10.** How to install Cam Wheels (L) and (R). (Refer to Fig. 6-6)

Set Cam Wheels (L) and (R) as indicated in Fig. 6-6.

The color of Cam Wheel (L) is black and (R) is white, and they rotate around the fulcrum provided by the Capstan Holder Part on the Chassis Mech Part.

**6-1-11.** The bottom view of Rotary head mechanism.

Refer to Fig. 6-7 when the assembly of this mechanism is necessary.

**6-1-12.** The relation between each mode and five mechanical parts.

Refer to Chart 2.















MODES		FWD	REV	FF	RWD	FF SEARCH (IPLS, INTRO SCAN)	RWD SEARCH (IPLS, INTRO SCAN)
PARTS							
ARM HEAD SHIFT	(L)	○	×	×	×	○	×
	(R)	×	○	×	×	×	○
ARM PLAY	(L)	×	○	×	×	×	×
	(R)	○	×	×	×	×	×
ARM RETURN	(L)	○	×	×	×	×	×
	(R)	×	○	×	×	×	×
ARM IDLER SHIFT	(L)	×	×	○	×	○	×
	(R)	×	×	×	○	×	○
CAM WHEEL	(L)						
	(R)						

Chart 2

○ : Related (Involved).

×

 : Rotation Direction Clockwise for +91 counts.

 : Counter-clockwise for -91 counts.

 : Clockwise for +43 counts and Counter-clockwise to +25 counts.

 : Counter-clockwise for -51 counts and Clockwise to -25 counts.

\* All the mode conditions are indicated relative to the Stop mode.

# VII. MECHANICAL ADJUSTMENT

## 7-1. PINCH ROLLER PRESSURE MEASUREMENT (Refer to Fig. 7-1)

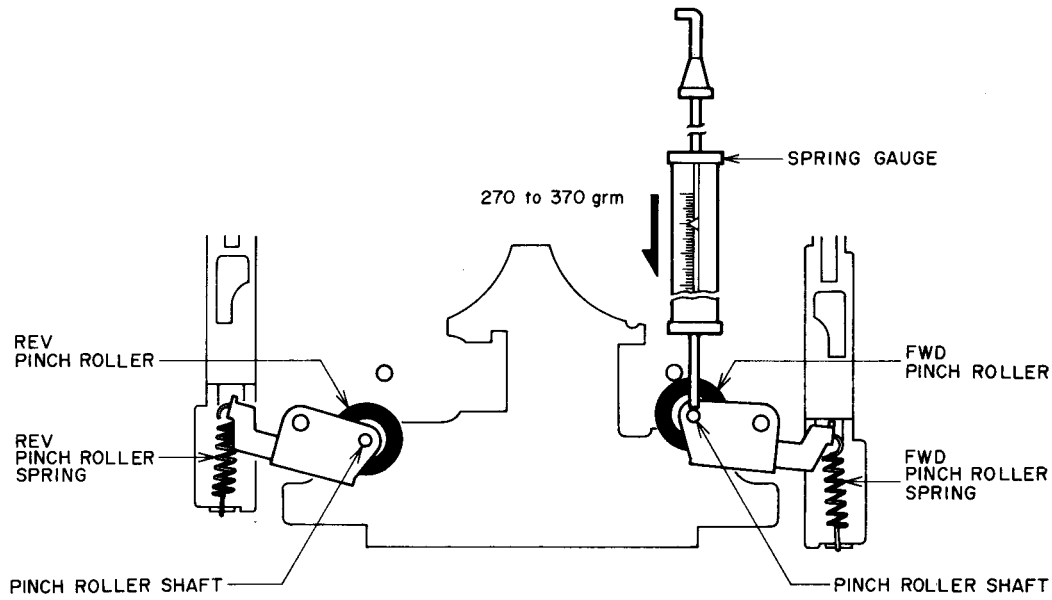

Fig. 7-1

Put in FWD PLAY Mode. Push pinch roller shaft down with the spring gauge, and push the pinch roller 1 to 2 mm away from the capstan and release slowly. Read the spring gauge at the moment the pinch roller

touches the capstan and begins to rotate. Specified contact pressure measurement is 270 to 370 grams. If the correct measurement is not obtained, replace the pinch roller spring. Do the same for the reverse side.

## 7-2. WINDING TORQUE MEASUREMENT IN EACH MODE (Refer to Fig. 7-2)

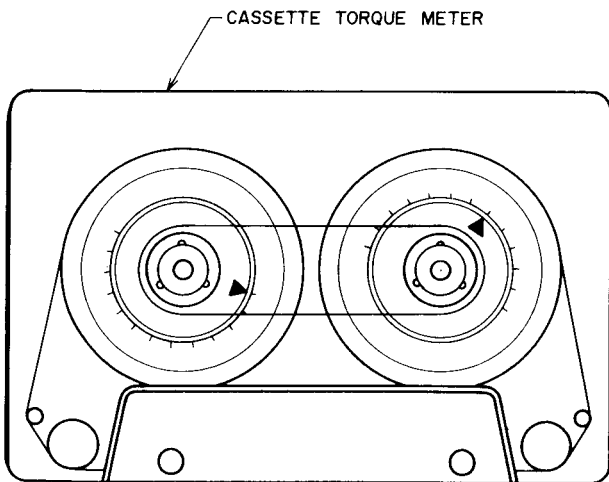

Fig. 7-2

Insert a cassette torque meter (AJ-751179) and measure in each mode.

For Fast Forward and Rewind, measure at the end of the tape when the tape has stopped running.

Forward or Reverse mode

Take up Torque: 25 to 45 g-cm

Back Tension Torque: 2 to 5 g-cm

Fast Forward or Rewind mode

Take up Torque: 70 to 150 g-cm

## 7-3. TAPE SPEED ADJUSTMENT (Refer to Fig. 7-3)

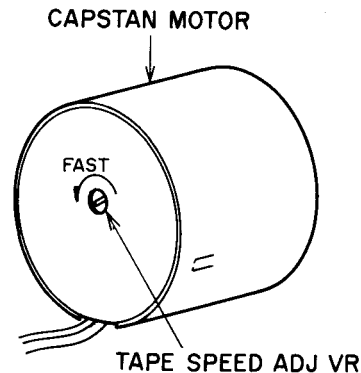

Fig. 7-3 Location of Tape Speed Adjustment Variable Resistor

Connect a frequency counter to Line Output terminal. Playback a 1,000 Hz pre-recorded Test Tape (AT-750744), or 3,150 Hz pre-recorded Test Tape (AT-751263), and adjust the Tape Speed Adjustment Variable Resistor (See Fig. 7-3) to obtain a tape speed of  $1002 \pm 3$  Hz, or  $3155 \pm 10$  Hz.

# VIII. HEAD ADJUSTMENT

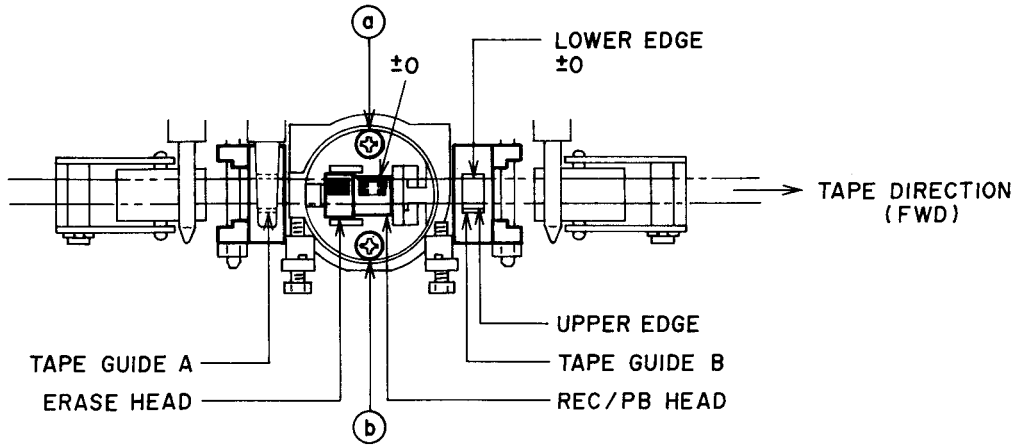

Fig. 8-1

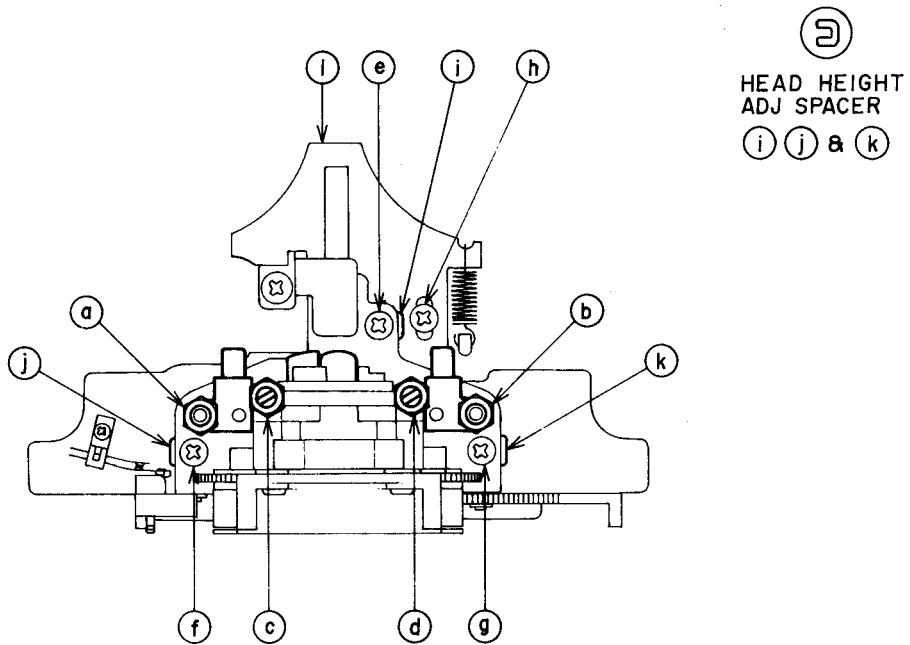

Fig. 8-2

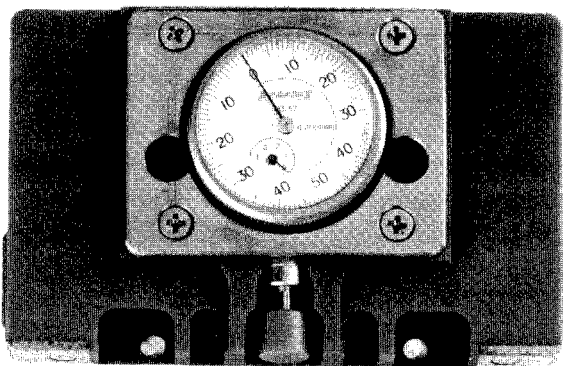

Fig. 8-3 Cassette Head Projection Gauge (TF-111CJ)



Fig. 8-4 Mirror Cassette Tape (MC-112C)

## 8-1. TAPE GUIDE ADJUSTMENT

(Refer to Figs. 8-1, 8-2 & 8-4)

- 1) Use a Mirror Cassette Tape (AT-751178) shown in Fig. 8-3 for better visibility of the head area, and select PLAY mode.
- 2) Adjust the tape guides A and B by turning the tape guide height adjustment nuts (a) and (b) in Fig. 8-2, so that the tape runs smoothly by the lower edge of both tape guides, and the tape is not hitched by those tape guides.

## 8-2. REC/PB HEAD AZIMUTH

### ADJUSTMENT

Playback a 10 kHz Head Azimuth Adjustment Tape (AT-750778) and adjust the screws (c) (FWD direction) and (d) (REV direction), so that the levels of both channels are maxima. (NOTE: Avoid turning the screws too far as other false maxima exist further away on both sides of the correct position.)

## 8-3. HEAD HEIGHT ADJUSTMENT

This adjustment is not necessary since these models (HX-R5, GX-R6) are equipped with Rotary Head System (with Erase & REC/PB combination head). However, the confirmation of head height is necessary and it can be done as follows.

- 1) Confirm the azimuth in item 8-2.
- 2) Playback a 315 Hz (or 333 Hz) PB Level Adjustment Tape (AT-750773) in FWD Play mode, and adjust the PB level Adjuster (VR5 on Pre-Amp P.C.Board) so that the LINE OUT level of left channel is  $-5.5$  dBm. Then, check the level of the same channel in REV mode. The difference in level between FWD and REV modes should be within  $\pm 1$  dBm. ( $-4.5$  dBm to  $-6.5$  dBm)
- 3) If the difference is more than  $\pm 1$  dBm in item 2), adjust the tape guides A & B by turning both Tape Guide Height Adjustment screws (a) & (b) in the same direction by  $1/4$  turn ( $\pm 0.1$  mm), so that difference is within  $\pm 1$  dBm.
- 4) The Head Height Adjustment is necessary if still the difference could not be corrected by above adjustment. It can be done by changing the Head Height Adjustment Spacers (i) (j) & (k). (The thicknesses of these spacers are (i) =  $0.45$  mm, (j) & (k) =  $0.3$  mm). Loosen the screws (e) (f) & (g) for the spacer replacement.

If the level is lower in REV mode, it means that the head is too high, therefore replace the spacers by thinner ones. When the level is higher in REV mode, replace them by thicker ones.

After the replacement of those spacers, do the same adjustment in item 1) and check the level of LINE OUT is  $-5.5$  dBm  $\pm 1$  dBm.

For the further confirmation, playback a 4 Track Head Height Adjustment Tape (1 kHz/4 Track, AT-750775). Line Output level of both channels should be more than  $-8$  dBm and the difference in level between FWD and REV modes should be within

$\pm 1$  dBm. Otherwise do the fine adjustment in the same manner as item 3) & 4).

- 5) When the head replacement is necessary, loosen only the screws (a) & (b) in Fig. 8-1 for easy replacement.

## 8-4. HEAD BLOCK PROJECTION

ADJUSTMENT (Refer to Figs. 8-2 & 8-3)

Use a Cassette Head Projection Gauge (AT-751180) and select FWD or REV play mode.

Loosen the screw (h) and adjust Chassis Head Part (l) so that the gauge indication at the time is  $3.2 \pm \begin{matrix} 0.15 \\ 0.05 \end{matrix}$  mm

(HX-R5) or  $3.4 \pm 0.1$  mm (GX-R6).

After the adjustment, apply paint-lock on the screw (h).

# IX. ELECTRICAL ADJUSTMENT

## 9-1. QUICK REVERSE SENSITIVITY ADJUSTMENT

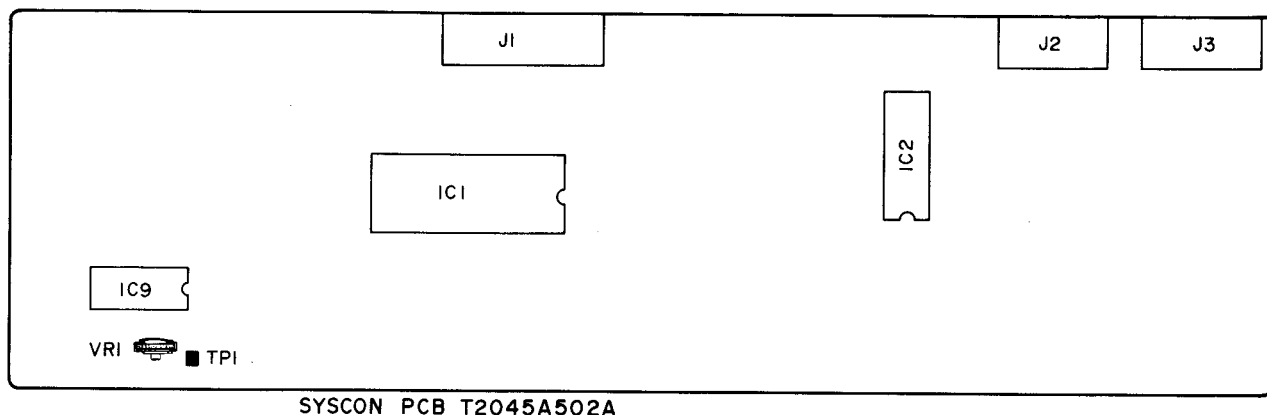

Fig. 9-1 Quick Reverse Sensitivity Adjustment Points

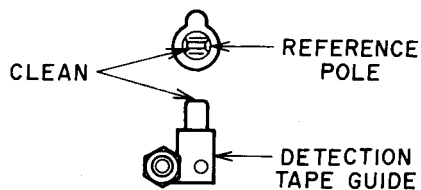

Fig. 9-2

1. Make a tapeless cassette pack by removing the tape from the white colored test tape.
2. Connect a Digital Voltmeter between TP-1 and Ground.
3. Using the tapeless cassette pack, adjust VR1 so that the Digital voltmeter reads  $12V \pm 0.5V$  DC at FWD play mode.
4. If the Digital voltmeter reading is not increase to 12V DC at VR1 maximum. Remove the Resister R51 (1 Mohms) from the system control P.C Board, and again adjust VR1 as the same manner in item 3).

**Note:**

Clean the reference pole and the Detection tape guide before adjustment. (Refer to Fig. 9-2)

## 9-2. PRE-AMP P.C BOARD ADJUSTMENT

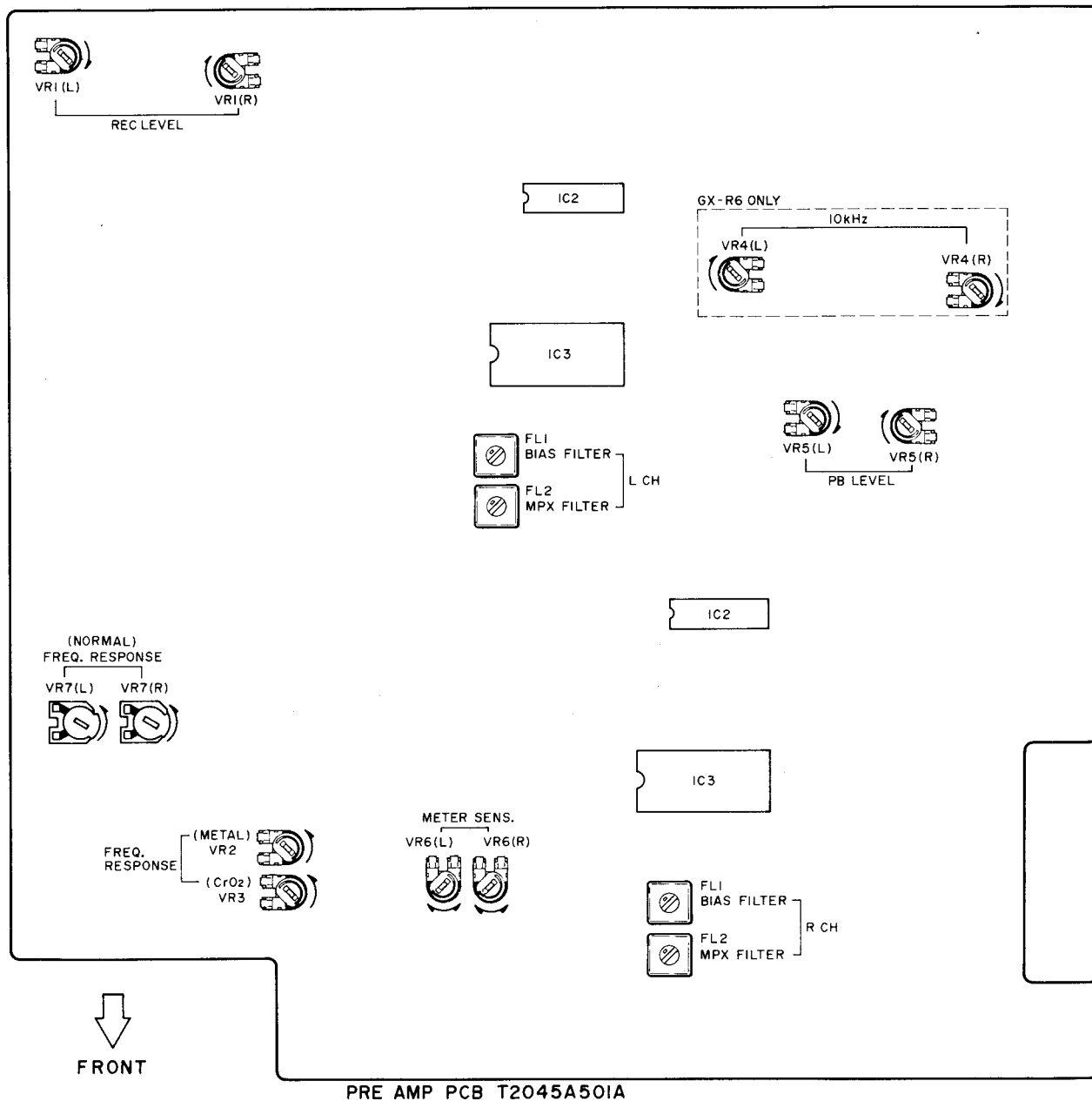

Fig. 9-3 Pre-Amp PCB ADJ Points



Step	Adjustment Item	Test Tape & Supply Signal	Mode	ADJ. Parts	Results	Remarks
1	FWD PB Level	333 Hz (AT-750773) or 315 Hz (AT-750773)	FWD PB	VR5	-6.1 ±0.2 dBm or -5.5 ±0.2 dBm	
2	REV PB Level	333 Hz (AT-750773) or 315 Hz (AT-750773)	REV PB		-6.1 ±1.0 dBm or -5.5 ±0.2 dBm	Confirmation
3	FWD PB EQ	10 kHz-15 dB (AT-750778)	FWD PB	VR4	-20.5 ±4 dBm	GX-R6 only
4	REV PB EQ	10 kHz-15 dB (AT-750778)	REV PB		-20.5 ±4 dBm	Confirmation
5	Normal Position Frequency Response	Normal Blank Tape 1 kHz, 10 kHz -25.5 dBm	REC/PB	VR7	1 kHz, 10 kHz Flat ±0.5 dB	Difference between Left and Right Channels are within 0.5 dB
6	CrO <sub>2</sub> Position Frequency Response	CrO <sub>2</sub> Blank Tape 1 kHz, 10 kHz -25.5 dBm	REC/PB	VR3	1 kHz, 10 kHz Flat ±0.5 dB	Difference between Left and Right Channels are within 0.5 dB
7	Metal Position Frequency Response	Metal Blank Tape 1 kHz, 10 kHz -25.5 dBm	REC/PB	VR2	1 kHz, 10 kHz Flat ±0.5 dB	Difference between Left and Right Channels are within 0.5 dB
8	REC Level	Normal Blank Tape 1 kHz, -5.5 dBm	REC/PB	VR1	-5.5 ±0.3 dBm	
9	Bias Filter	No Signal input	REC	FL1	Minimum output	Set REC Volume to maximum
10	Meter Sensitivity	1 kHz input	REC PAUSE	VR6	+1 VU extinguishes at Line output -5.2 dBm	Confirm that OVU indication at line output -5.8 dBm
11	MPX Filter	19 kHz from oscillator	REC	FL2	Minimum output	MPX Filter switch "ON" (GX-R6 only)

Note: Refer to Fig. 9-3 for these adjustments.

## X. DC RESISTANCE OF HEADS

### Model HX-R5

DESCRIPTION	DC RESISTANCE
REC/PB HEAD	360 ohms $\pm$ 25%
ERASE HEAD	3.5 ohms

### Model GX-R6

DESCRIPTION	DC RESISTANCE
REC HEAD	50 ohms $\pm$ 10%
P.B HEAD	340 ohms $\pm$ 10%
ERASE HEAD	3.5 ohms $\pm$ 10%

## XI. CLASSIFICATION OF VARIOUS P.C BOARDS

### 11-1. P.C BOARD TITLES AND IDENTIFICATION NUMBERS

P.C BOARD TITLE	P.C BOARD NUMBER	REMARK
PRE-AMP P.C Board	T2045A501A	
JACK P.C Board	T2045A501B	
OUTPUT P.C Board	T2045A501C	GX-R6 only
SYSCON P.C Board	T2045A502A	
METER P.C Board	T2045A502B	
POWER SUPPLY P.C Board	T2045C5030	U.J.
POWER SUPPLY P.C Board	T2045C5031	C.A.
POWER SUPPLY P.C Board	T2045C5032	E.V.B.S.
CONTROL P.C Board	CMR01C189B	
FLEXIBLE P.C Board	CMR01A0240	GX-R6
FLEXIBLE P.C Board	CMR01A0020	HX-R5
LEAF SWITCH P.C Board	CMR01C1490	
CAM MOTOR PULSE P.C Board	CMR01C189B	
CAM MOTOR DIRECTION P.C Board	CMR01C189C	
REEL ROTATION P.C Board	CMR01D1440	
DETECTOR (A) P.C Board	CMR01D1290	
DETECTOR (B) P.C Board	CMR01D1620	
GUIDE DETECTOR P.C Board	CMR01D0220	
HOUSING P.C Board	CMR01D1430	

# 11-2. COMPOSITION OF VARIOUS P.C BOARD

## 1) HX-R5 PRE-AMP P.C BOARD T2045A501A · JACK P.C BOARD T2045A501B

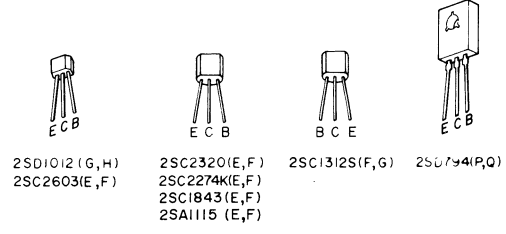
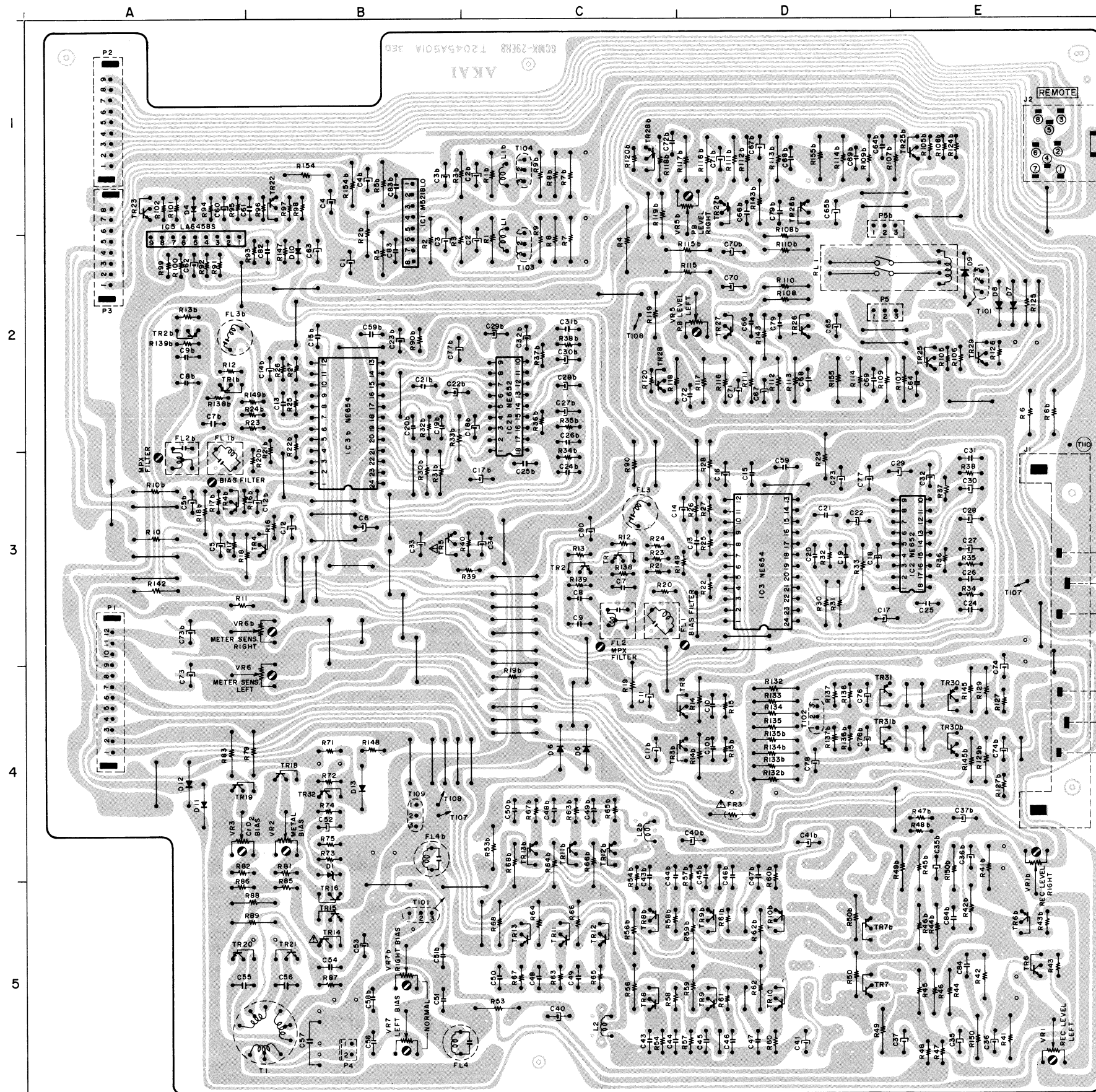
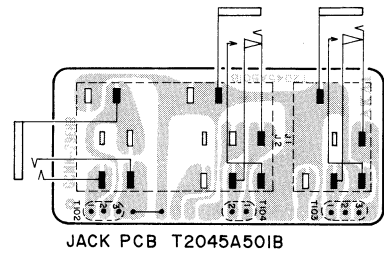

- TR 1 to 4, 8 to 13  
TR 7, 25, 26  
TR 5  
TR 6  
TR 14, 20, 21  
TR 15, 16, 18, 19  
TR 22, 23, 29, 32  
TR 26  
TR 27  
TR 30, 31
- 2SC2320(E,F)  
2SD794(P,Q)  
2SD1012(P,Q)  
2SC2274K(E,F)  
2SC2603 (E,F)  
2SC1843(E,F)  
2SC1312S(F,G)  
2SA1115 (E,F)

### LOCATION OF COMPONENTS

#### TR

- TR1, 2.....C3
- TR1b, 2b.....A2
- TR3, 3b.....D4
- TR4, 5.....B3
- TR4b.....A3
- TR6, 6b.....E5
- TR7, 7b.....D5
- TR8, 8b.....C5
- TR9, 9b, 10, 10b...D5
- TR11 to 13.....C5
- TR11b to 13b.....C4
- TR14 to 16.....B5
- TR18.....B4
- TR19.....A4
- TR20.....A5
- TR21.....B5
- TR22.....B1
- TR23.....A1
- TR25.....E2
- TR25b.....E1
- TR26, 27.....D2
- TR26b, 27b.....D1
- TR28.....C2
- TR29.....E2
- TR30, 30b.....E4
- TR31, 31b.....D4
- TR32.....B4

#### IC

- IC1.....B1
- IC2.....E3
- IC2b.....C2
- IC3.....D3
- IC3b.....B2
- IC5.....A1

#### TERMINAL

- P1.....A3
- P2, 3.....A1
- P4.....B5
- P5.....D2
- P5b.....D1
- J1.....E3
- J2.....E1
- T110.....E2
- T102.....D4
- T103, 104.....C1
- T109.....B4

WARNING: ⚠ INDICATES SAFETY CRITICAL COMPONENTS. FOR CONTINUED SAFETY, REPLACE SAFETY CRITICAL COMPONENTS ONLY WITH MANUFACTURER'S RECOMMENDED PARTS.

AVERTISSEMENT: ⚠ IL INDIQUE LES COMPOSANTS CRITIQUES DE SÉCURITÉ. POUR MAINTENIR LE DEGRÉ DE SÉCURITÉ DE L'APPAREIL, NE REMPLACER QUE DES PIÈCES RECOMMANDÉES PAR LE FABRICANT.

2) GX-R6 PRE-AMP P.C BOARD T2045A501A · JACK P.C BOARD T2045A501B · OUTPUT P.C BOARD T2045A501C

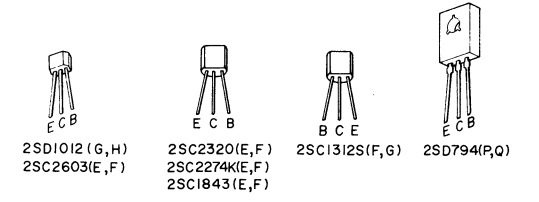
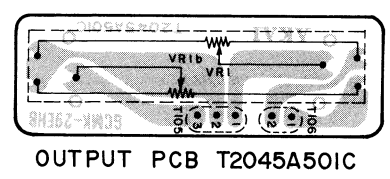
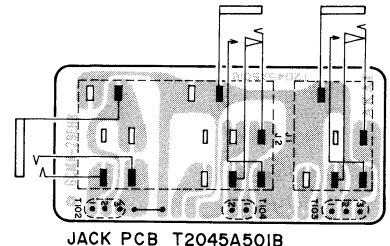
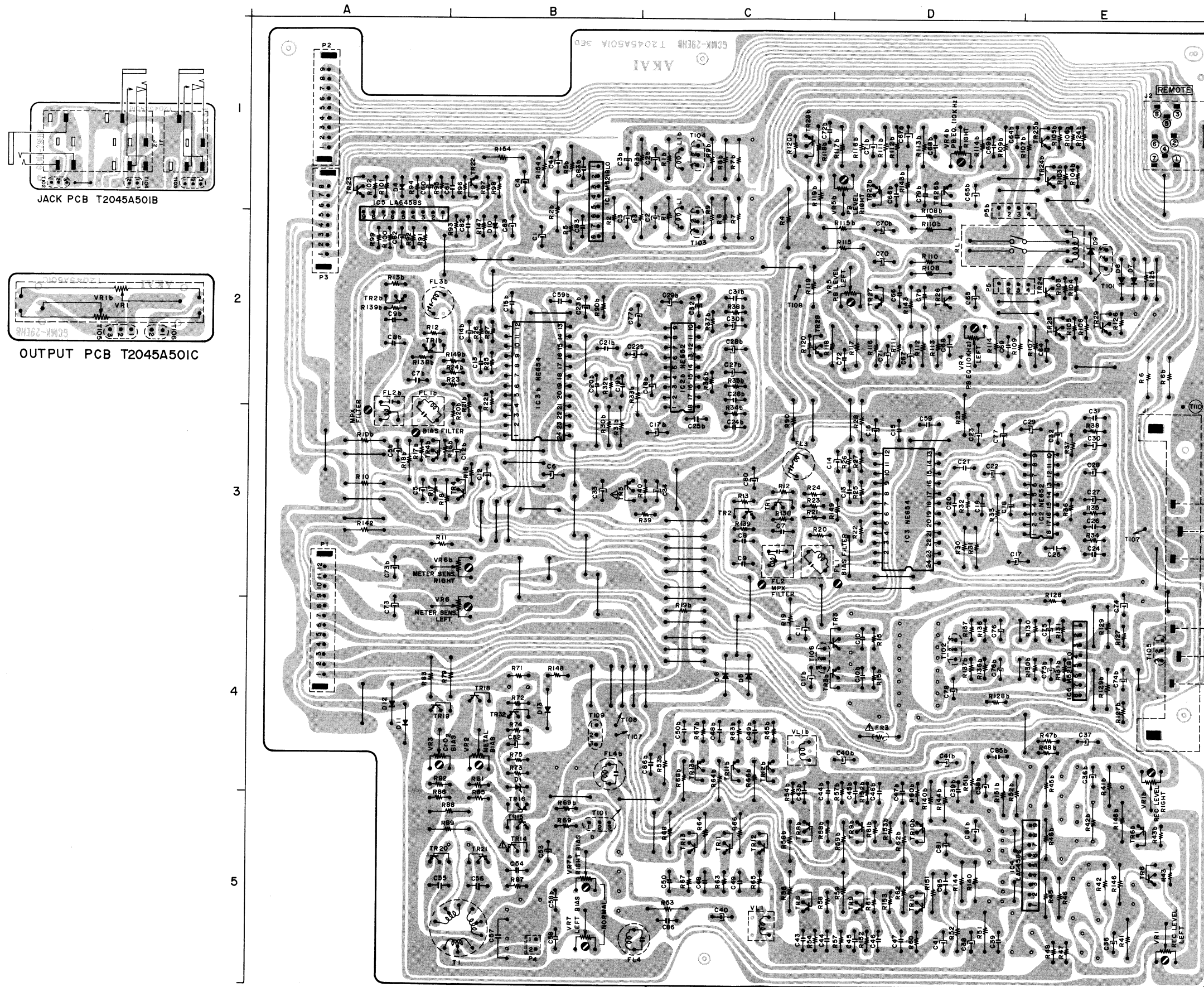

- TR 1 to 4, 8 to 13 ----- 2SC2320 (E, F)
- TR 24, 25, 28 ----- 2SD794 (P, Q)
- TR 5 ----- 2SD1012 (G, H)
- TR 14, 20, 21 ----- 2SC2274K (E, F)
- TR 15, 16, 18, 19 ----- 2SC2603 (E, F)
- TR 22, 23, 29, 32 ----- 2SC1843 (E, F)
- TR 27 ----- 2SC132S (F, G)

LOCATION OF COMPONENTS

- IC
- IC 1 ----- B1
  - IC 2 ----- E3
  - IC 2b ----- C2
  - IC 3 ----- D3
  - IC 3b ----- B2
  - IC 4 ----- E5
  - IC 5 ----- A1
  - IC 6 ----- E4

- TR
- TR 1, 2 ----- C3
  - TR 1b, 2b ----- A2
  - TR 3, 3b ----- D4
  - TR 4, 5 ----- B3
  - TR 4b ----- A3
  - TR 6, 6b ----- E5
  - TR 8, 8b ----- C5
  - TR 9, 9b, 10, 10b ----- D5
  - TR 11 to 13 ----- C5
  - TR 11b to 13b ----- C4
  - TR 14 to 16 ----- B5
  - TR 18 ----- B4
  - TR 19 ----- A4
  - TR 20 ----- A5
  - TR 21 ----- B5
  - TR 22 ----- B1
  - TR 24, 25 ----- E2
  - TR 24b, 25b ----- E1
  - TR 26, 27 ----- D2
  - TR 26b, 27b ----- D1
  - TR 28 ----- C2
  - TR 28b ----- C1
  - TR 29 ----- E2
  - TR 32 ----- B4
  - TR 23 ----- A1

- TERMINAL
- P 1 ----- A3
  - P 2, 3 ----- A1
  - P 4 ----- B5
  - P 5 ----- D2
  - P 5b ----- D1
  - J 1 ----- E3
  - J 2 ----- E1
  - T10 ----- E2
  - T102 ----- D4
  - T103, 104 ----- C1
  - T105 ----- F4
  - T106 ----- C4
  - T109 ----- B4

WARNING: INDICATES SAFETY CRITICAL COMPONENTS FOR CONTINUED SAFETY. REPLACE SAFETY CRITICAL COMPONENTS ONLY WITH MANUFACTURER'S RECOMMENDED PARTS.

AVERTISSEMENT: INDIQUE LES COMPOSANTS CRITIQUES DE SÉCURITÉ. POUR MAINTENIR LE DEGRÉ DE SÉCURITÉ DE L'APPAREIL, NE REMPLACER QUE DES PIÈCES RECOMMANDÉES PAR LE FABRICANT.

PRE-AMP PCB T2045A501A

3) SYSTEM CONTROL P.C BOARD T2045A502A · METER P.C BOARD T2045A502B

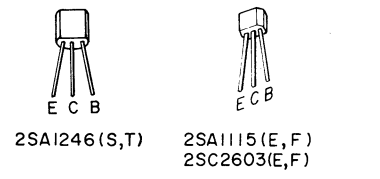
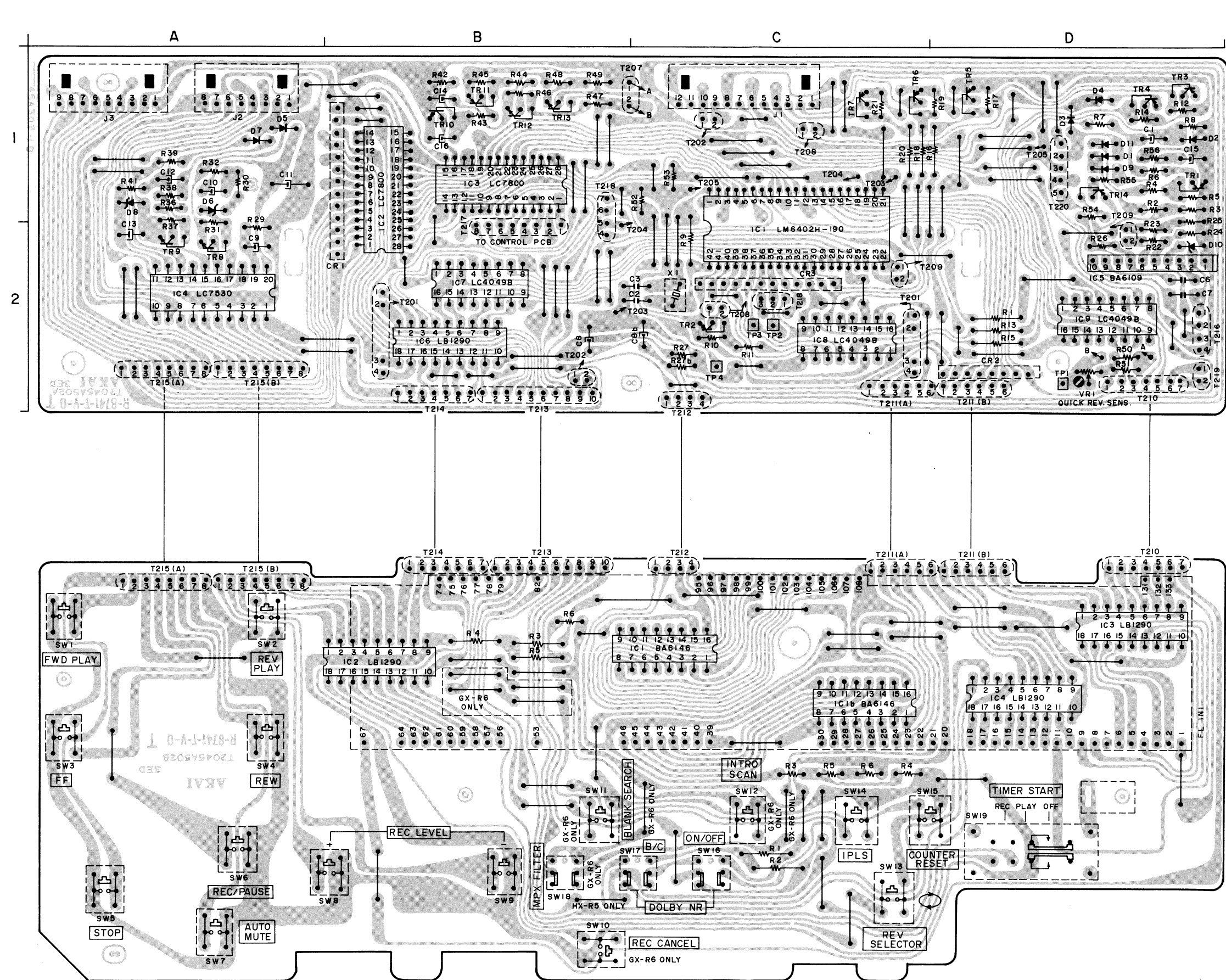

TR1, 8 to 10, 12, 13    2SC2603(E,F)  
TR2, 3, 5 to 7, 11, 14    2SA1115(E,F)  
TR4    2SA1246(S,T)

LOCATION OF COMPONENTS

TR	IC
TR1 --- D1	IC1 --- C1
TR2 --- C2	IC2, 3 --- B1
TR3 to 5 --- D1	IC4 --- A2
TR6, 7 --- C1	IC5 --- D2
TR8, 9 --- A2	IC6, 7 --- B2
TR10 to 13 --- B1	IC8 --- C2
TR14 --- D1	IC9 --- D2

TERMINAL

J1	--- C1
J2, 3	--- D1
T210	--- A2
T211(A)	--- C2
T211(B)	--- D2
T212	--- C2
T213, 214	--- B2
T215(A, B)	--- A2
T216	--- D2
T217, 218	--- B1
T218	--- C2
T219	--- D2
T220	--- D1

SYSCON PCB T2045A502A

METER PCB T2045A502B

4) POWER SUPPLY P.C BOARD T2045C5030 (U, J MODEL) · T2045C5031 (C, A MODEL) · T2045C5032 (E, V, B, S MODEL)

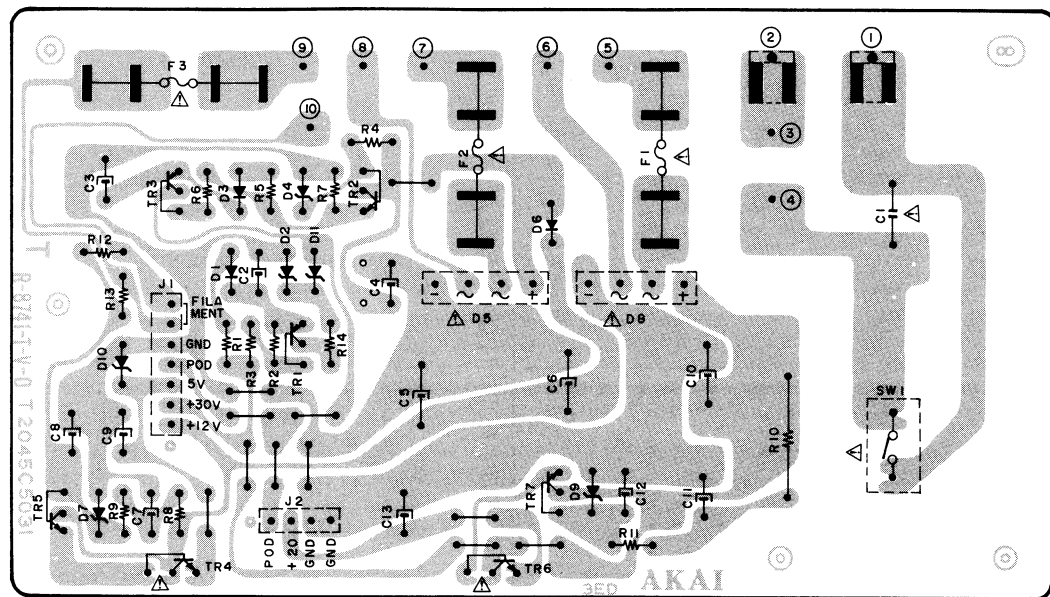

POWER SUPPLY PCB  
T2045C5030 U J  
5031 C A  
5032 E V B S

WARNING: Δ INDICATES SAFETY CRITICAL COMPONENTS. FOR CONTINUED SAFETY, REPLACE SAFETY CRITICAL COMPONENTS ONLY WITH MANUFACTURER'S RECOMMENDED PARTS.  
AVERTISSEMENT: Δ IL INDIQUE LES COMPOSANTS CRITIQUES DE SÉCURITÉ. POUR MAINTENIR LE DEGRÉ DE SÉCURITÉ DE L'APPAREIL, NE REMPLACER QUE DES PIÈCES RECOMMANDÉES PAR LE FABRICANT.

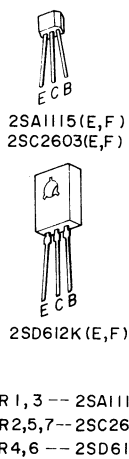

TR 1, 3 -- 2SA1115 (E, F)  
TR 2, 5, 7 -- 2SC2603 (E, F)  
TR 4, 6 -- 2SD612K (E, F)

5) OTHER P.C BOARDS

CONTROL PCB CMR01C189A

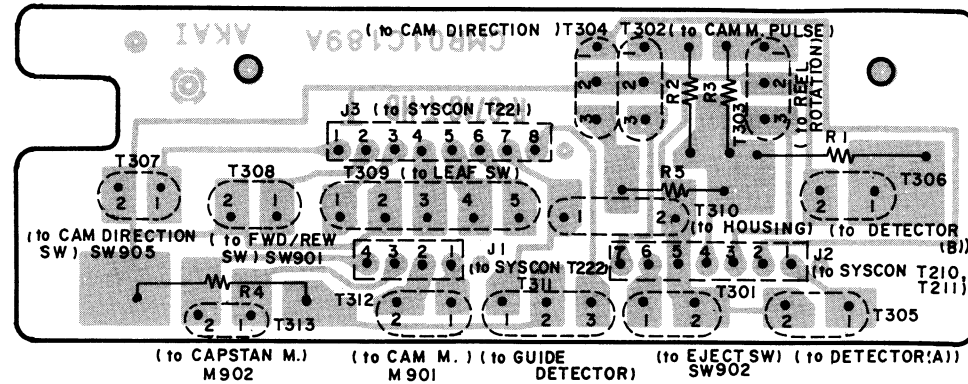

HX-R5

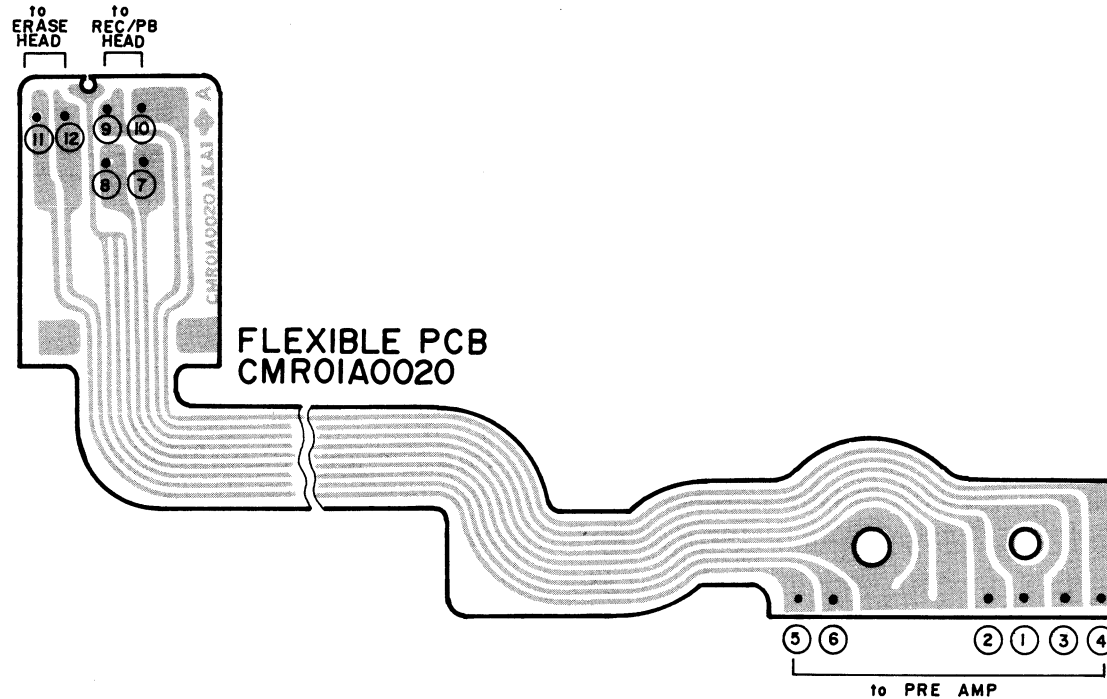

GX-R6

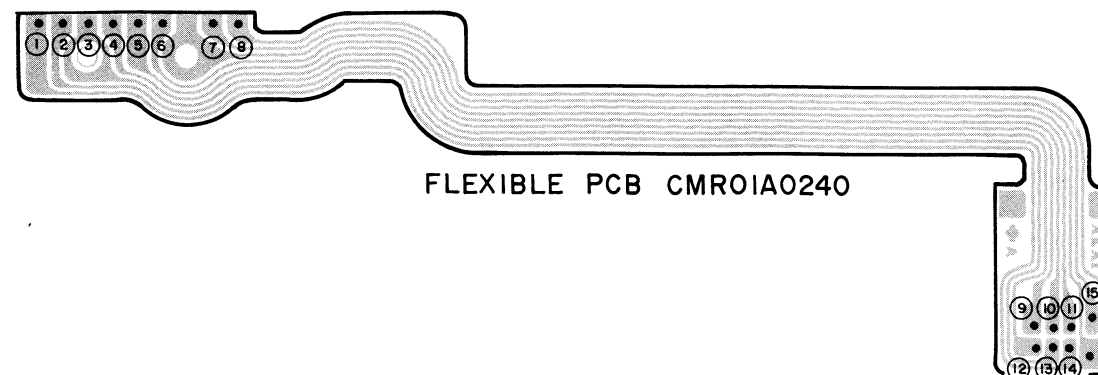

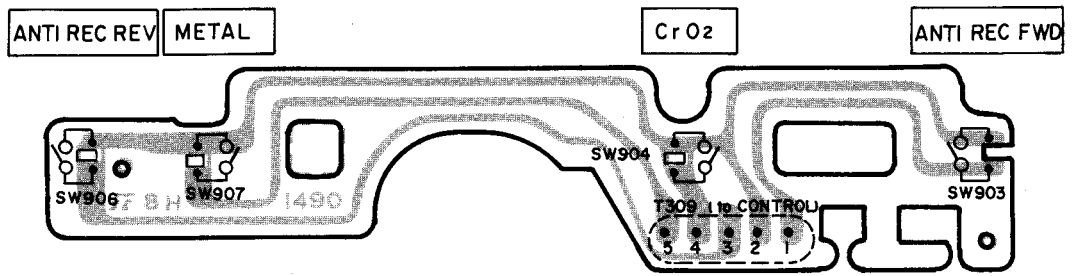

LEAF SWITCH PCB CMROIC1490

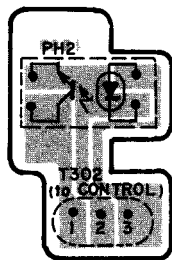

CAM MOTOR  
PULSE PCB  
CMROIC189B

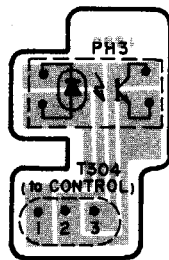

CAM DIRECTION  
PCB  
CMROIC189C

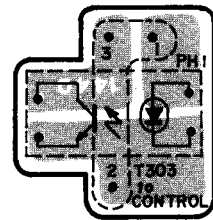

REEL ROTATION  
PCB CMROID1440

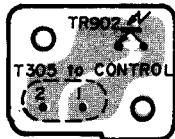

DETECTOR(A) PCB  
CMROID1290

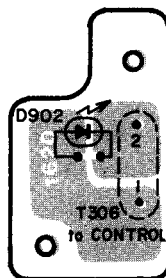

DETECTOR(B) PCB  
CMROID1620

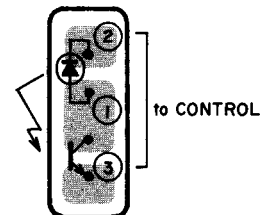

GUIDE DETECTOR  
PCB CMROID0220

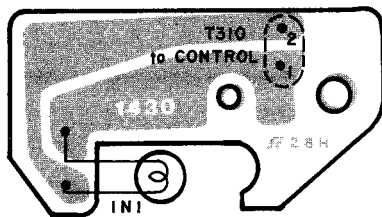

HOUSING PCB  
CMROID1430













---

SECTION 2

**PARTS LIST**

TABLE OF CONTENTS

RECOMMENDED SPARE PARTS (HX-R5).....	37
1. MECHA CMR01 BLOCK.....	39
2. PRE-AMP P.C BOARD BLOCK.....	40
3. SYSTEM CONTROL	
P.C BOARD BLOCK.....	40
4. POWER SUPPLY P.C BOARD BLOCK.....	40
5. ASSEMBLY BLOCK.....	41
6. FINAL ASSEMBLY BLOCK.....	42
RECOMMENDED SPARE PARTS (GX-R6).....	43
1. MECHA CMR01 BLOCK.....	45
2. PRE-AMP P.C BOARD BLOCK.....	46
3. SYSTEM CONTROL P.C BOARD BLOCK.....	46
4. POWER SUPPLY P.C BOARD BLOCK.....	46
5. ASSEMBLY BLOCK.....	47
6. FINAL ASSEMBLY BLOCK.....	48
INDEX.....	49

Please refer to COMMON LIST FOR SERVICE PARTS, for Resistor and Capacitor which are not listed in this list.

## ATTENTION

1. When placing an order for parts, be sure to list the parts no., model no., and description. There are instances in which if any of this information is omitted, parts cannot be shipped or the wrong parts will be delivered.
2. Please be careful not to make a mistake in the parts no. If the parts no. is in error, a part different from the one ordered may be delivered.
3. Because parts number and parts unit supply in the Preliminary Parts List may be partially changed, please use this parts list for all future reference.

## HOW TO USE THIS PARTS LIST

1. This Parts List shows the parts that are considered necessary for repairs. Other parts, such as resistors and capacitors, are shown in the "Common List for Service Parts". Select and order such parts from the "Common List for Service Parts".
2. The Recommended Spare Parts shows those parts in the Parts List which are considered particularly important for service.
3. Parts not shown in the Parts List and "Common List for Service Parts" will not be supplied in principle.
4. How to read list
  - a) Mechanism Block
  - b) P.C Board Block

### 2. HEAD BASE BLOCK

REF. NO.	PARTS NO.	DESCRIPTION
2-1x	BH-T2023A320A	HEAD BASE BLOCK GX-F66R
2-2	HP-H2206A010A	HEAD R/P PR4-8FU C
2-3	ZS-477876	PAN20x03STL CMT
2-4	ZS-536488	BID20x08STL CMT
2-5	ZG-402895	CS ANGLE ADJUST SPRING

SP (Service Parts) Classification  
 A small "x" indicates the inability to show that particular part in the Photo or Illustration.  
 This number corresponds with the individual parts index number in that figure  
 This number corresponds with the Figure Number

### 6. SYS. CON. P.C BOARD BLOCK

REF. NO.	PARTS NO.	DESCRIPTION
6-1	BA-T2034A070A	PC SYS CON BLK GX-F44R
6-IC1	EI-324536	IC HD14049BP
6-IC2	EI-336801	IC MB8841-564M
6-IC3	EI-331661	IC SN7405N
6-IC4	EI-336725	IC M54527P
6-TR1to4	ET-200985	TR 2SC2603 F,G
6-TR5to28	ET-554657	TR 2SA733A P,Q
6-D1	ED-318292	D SILICON H 1S2473T-77 T26
6-D2to4	ED-308952	D GERMA V 1K34A-LR F07
6-D5to10	ED-318292	D SILICON H 1S2473T-77 T26
6-X1	EI-318384	OSC X'TAL NC-18C 3.579545MHZ

SP (Service Parts) Classification  
 This reference numbers corresponds with symbol numbers of Schematic Diagrams.

5. Both the kind of part and installation position can be determined by the Parts Number. To determine where a parts number is listed, utilize Parts Index at end of Parts List. It is necessary first of all to find the Parts Number. This can be accomplished by using the Reference Number listed at right of parts number in the Parts Index.

## WARNING

△ INDICATES SAFETY CRITICAL COMPONENTS. FOR CONTINUED SAFETY, REPLACE SAFETY CRITICAL COMPONENTS ONLY WITH MANUFACTURER'S RECOMMENDED PARTS.

## AVERTISSEMENT

△ IL INDIQUE LES COMPOSANTS CRITIQUES DE SÉCURITÉ. POUR MAINTENIR LE DEGRÉ DE SÉCURITÉ DE L'APPAREIL, NE REMPLACER QUE DES PIÈCES RECOMMANDÉES PAR LE FABRICANT

# I. MODEL HX-R5

HX-R5

## RECOMMENDED SPARE PARTS

Because, if the parts listed below are on hand, almost any repair can be accomplished, we suggest that you stock these Recommended Spare Parts Items.

REF. NO.	PARTS NO.	DESCRIPTION			
1	BF-344029	FLYWHEEL	66	ES-344270	△ SW PUSH SDDL1P 01-1
2	BH-T2045A030A	HEAD BLK HX-R5	67	ES-305733	△ SW SELECTOR HXW0131-260 01-4 (VS901) (U ONLY)
3	BL-T2045A050A	ARM PINCH ROLLER (L) BLK HX-R5	68	ES-344104	SW LEAF BSW-191 01-1 NO (SW901)
4	BL-T2045A060A	ARM PINCH ROLLER (R) BLK HX-R5	69	ES-344101	SW LEAF MD-1003 01-1 NO (SW905)
5	BM-B604491	MOTOR (PULLEY) PART EG-510ED 2B2	70	ES-336814	SW LEAF MSW-1150NBK 01-1 NO (SW902)
6	BM-B604490	MOTOR OPERATION (PULLEY) PART	71	ES-344253	SW LEAF MSW-1418J 01-1 NO (SW904)
7	BR-344098	REEL TABLE (A) ASSY	72	ES-344257	SW LEAF MSW-1418L 01-1 NO (SW903)
8	BT-345835	△ TRANS POWER T2045 (B,S) (T901)	73	ES-337843	SW PUSH ESB-64501 02-2
9	BT-345833	△ TRANS POWER T2045 (C,A) (T901)	74	ES-345838	SW SLIDE 00230745 2-02-03N
10	BT-345834	△ TRANS POWER T2045 (E,V) (T901)	75	ES-336780	SW TACT KHH10902
11	BT-345832	△ TRANS POWER T2045 (J) (T901)	76	ET-310148	△ TR 2SD612K E, F
12	BT-345831	△ TRANS POWER T2045 (U) (T901)	77	ET-311977	PHOTO SENSOR SPI-201 (PH1)
13	BZ-T2045A040A	GUIDE DETECTION BLK HX-R5	78	ET-310341	TR PHOTO PT350 T (TR902)
14	EC-345808	C COMP 05-0047	79	ET-344102	TR PHOTO GP-1S04 (PH2)
15	ED-330319	△ D SILICON DBA10B 100/1.0A	80	ET-200558	TR 2SA1115 E, F
16	ED-310340	D LED GL-350 INFRARED RAY (D902)	81	ET-346298	TR 2SA1246 S, T
17	ED-301911	D SILICON H DS448	82	ET-330607	TR 2SC1312S F, G
18	ED-337575	D SILICON H GMA-01-4-BT T26	83	ET-337258	TR 2SC1843 E, F
19	ED-560913	D SILICON V 1S2473VE	84	ET-309353	TR 2SC2274K E, F
20	ED-306109	D SILICON W03B 100/1.0A	85	ET-328578	TR 2SC2320 E, F
21	ED-337776	D ZENER H HZ3C1	86	ET-200505	TR 2SC2603 E, F
22	ED-337868	D ZENER V HZ20-3S1	87	ET-328868	TR 2SD1012-V G, H
23	ED-338013	D ZENER V HZ24-3S1	88	ET-307349	TR 2SD794 P, Q
24	ED-336998	D ZENER V HZ6B-2S1	89	EV-345612	R S-FIX H H0811C329A 3P 302
25	ED-345822	D ZENER V HZ6C-3S1	90	EV-342940	R S-FIX H H0811C344A 3P 203
26	ED-345821	D ZENER V HZ7A-1S1	91	EV-342942	R S-FIX H H0811C345A 3P 503
27	ED-345820	D ZENER V HZ9B-2S1	92	EV-338467	R S-FIX H TM8K 3P 0.30W 104
28	ED-338454	D ZENER V HZ9C-2S1	93	EV-522652	R S-FIX V V8K1-1 3P 105
29	EF-668474	△ FUSE SEMKO T 250V 0.40A (F3) (E, V, B, S)	94	HR-344103	HEAD COMBO HD425804RVJ
30	EF-601942	△ FUSE SEMKO T 250V 0.63A (F2) (E, V, B, S)	95	MB-344088	BELT CAM
31	EF-601942	△ FUSE SEMKO T 250V 0.63A (F1) (E, V, B, S)	96	MB-344041	BELT CAPSTAN
32	EF-309389	△ FUSE TSC A 250V 0.40A (F3) (U, J)	97	MB-344042	BELT WIND (A)
33	EF-306124	△ FUSE TSC A 250V 0.63A (F2) (U, J)	98	MB-344043	BELT WIND (B)
34	EF-306124	△ FUSE TSC A 250V 0.63A (F1) (U, J)	99	MB-344028	PULLEY RUBBER
35	EF-308848	△ FUSE TSC 125V 0.40A (F3) (C, A)	100	MI-344095	IDLER PLAY (L) ASSY
36	EF-305703	△ FUSE TSC 125V 0.63A (F2) (C, A)	101	MI-344094	IDLER PLAY (R) ASSY
37	EF-305703	△ FUSE TSC 125V 0.63A (F1) (C, A)			
38	EI-330352	IC BA6109			
39	EI-337845	IC BA6146 M			
40	EI-336761	IC LA6458S			
41	EI-337013	IC LB1290			
42	EI-337009	IC LC4049B			
43	EI-345759	IC LC7530			
44	EI-337008	IC LC7800			
45	EI-345758	IC LM6402H-155			
46	EI-337228	IC M5218LO			
47	EI-337835	IC NE652			
48	EI-344291	IC NE654			
49	EI-337017	OSC CE CSB800A 0.800000MC			
50	EJ-346076	DIN J TCS4690-01-1111 P 8P			
51	EJ-345812	PHONE J HLJ0527-714 2P×2			
52	EJ-344640	PHONE J 2P HLJ4308-034 6.3 1T			
53	EJ-347664	PIN J YKC21-5053 P 4P			
54	EL-348214	PL LEAD 28.0V 24MA (IN1)			
55	EM-345810	IND FL FIP48AW16Y DOUBLE			
56	EO-347162	COIL FIX 1 L-8 10 MHz J			
57	EO-669273	COIL FIX 2 FL5R200 18μH			
58	EO-337044	COIL FIX 2 102AK-005 36 MH			
59	EO-345760	COIL OSC 1 32-5009-12 100 KHz			
60	EO-315758	COIL TUN 1 100S-431 100.00KC			
61	ER-318248	△ R FUSE ERD2FC S10 1/4W 47R0G			
62	ER-337695	FILTER DB 201AK-005 100KC			
63	ER-337696	FILTER DB 201AK-006 19 KHz			
64	ER-344278	R COMP 01-0371			
65	ER-345757	R COMP 01-0517			

MECHA CMR01 BLOCK

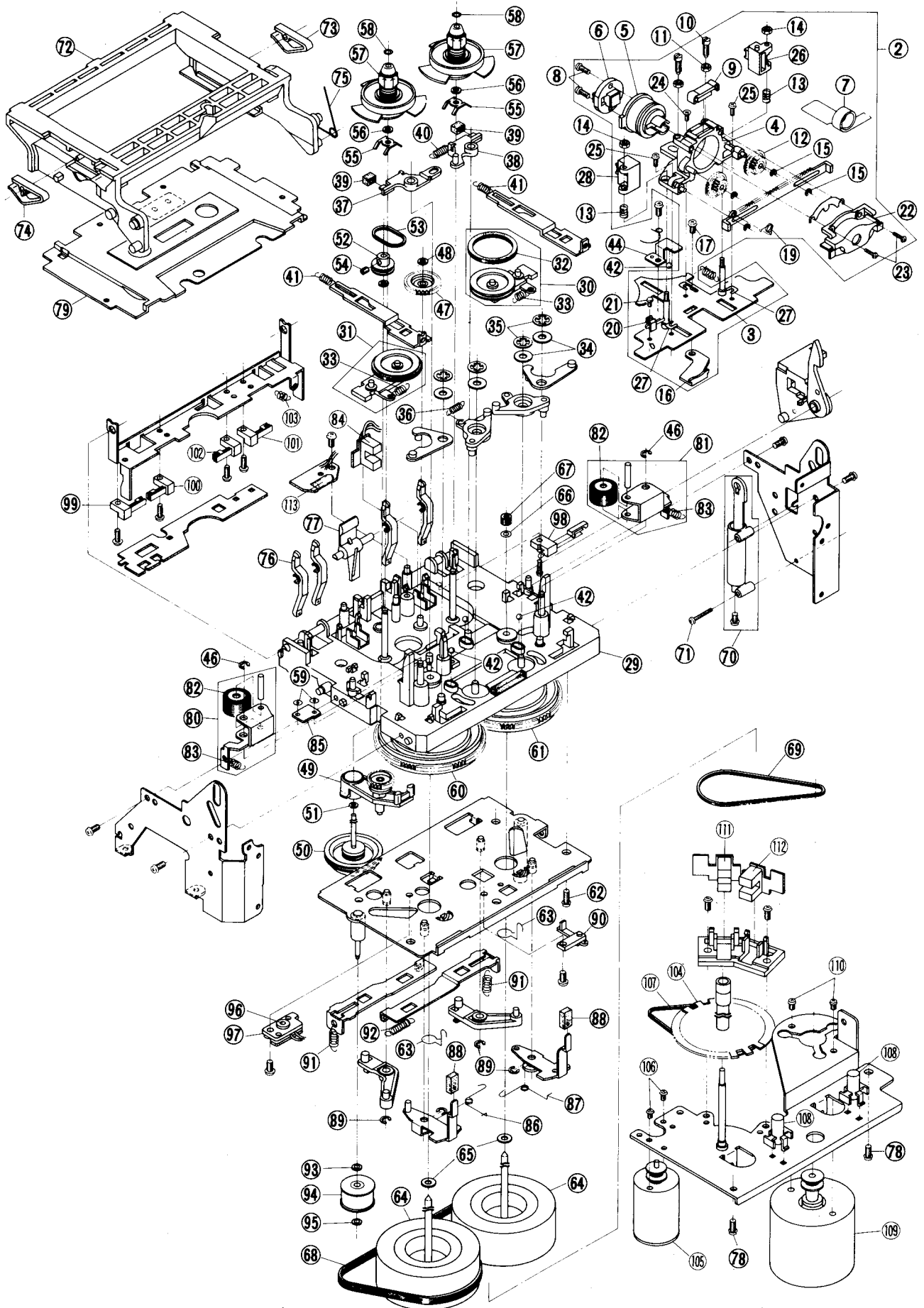





## 2. PRE-AMP P.C BOARD BLOCK

REF. NO.	PARTS NO.	DESCRIPTION
2-1	BA-T2045A170A	PC PRE-AMP BLK HX-R5
<b>PRE-AMP P.C BOARD</b>		
2-IC1A	EI-337228	IC M5218L0
2-IC2A	EI-344291	IC NE654
2-IC3A	EI-337835	IC NE652
2-IC5A	EI-336761	IC LA6458S
2-TR1A to 4A	ET-328578	TR 2SC2320 E,F
2-TR5A	ET-307349	TR 2SD794 P,Q
2-TR6A	ET-328868	TR 2SD1012-V G,H
2-TR7A to 13A	ET-328578	TR 2SC2320 E,F
2-TR14A	ET-309353	TR 2SC2274K E,F
2-TR15A, 16A	ET-200505	TR 2SC2603 E,F
2-TR18A, 19A	ET-200505	TR 2SC2603 E,F
2-TR20A, 21A	ET-309353	TR 2SC2274K E,F
2-TR22A, 23A	ET-200505	TR 2SC2603 E,F
2-TR25A, 26A	ET-328578	TR 2SC2320 E,F
2-TR27A	ET-330607	TR 2SC1312S F,G
2-TR28A	ET-328578	TR 2SC2320 E,F
2-TR29A	ET-200505	TR 2SC2603 E,F
2-TR30A, 31A	ET-200558	TR 2SA1115 E,F
2-TR32A	ET-200505	TR 2SC2603 E,F
2-D1A	ED-337776	D ZENER H HZ3C1
2-D4A	ED-337575	D SILICON H GMA-01-4-BT T26
2-D5A to 9A	ED-301911	D SILICON H DS448
2-D10A	ED-337575	D SILICON H GMA-01-4-BT T26
2-D11A to 13A	ED-301911	D SILICON H DS448
2-VR1A	EV-342940	R S-FIX H H0811C344A 3P 203
2-VR2A	EV-345612	R S-FIX H H0811C329A 3P 302
2-VR3A	EV-342940	R S-FIX H H0811C344A 3P 203
2-VR5A, 6A	EV-342942	R S-FIX H H0811C-345A 3P 503
2-VR7A	EV-338467	R S-FIX H TM8K 3P 0.30W 104
2-RL1A	EP-337067	RELAY LEAD LAB2NS 2NO 18V
2-T1A	EO-345760	COIL OSC 1 32-5009-12 100 kHz
2-L1A	EO-669273	COIL FIX 2 FL5R200 18μH
2-L2A	EO-347162	COIL FIX 1 L-8 10MHz J
2-FL1A	ER-337695	FILTER DB 201AK-005 100KC
2-FL2A	ER-337696	FILTER DB 201AK-006 19kHz
2-FL3A	EO-337044	COIL FIX 2 102AK-005 36MH
2-FL4A	EO-315758	COIL TUN 1 100S-431 100.00KC
2-J1A	EJ-347664	PIN J YKC21-5053 P 4P
2-J2A	EJ-346076	DIN J TCS4690-01-1111 P 8P
2-FR3A	ER-318248	△ R FUSE ERD2FC S10 1/4W 47ROG
2-R4A	ER-326616	R OMF H SNP FS 1W 681J
2-C57A	EC-337777	C PP V F10 ECQ-F 272J 630DC
2-C61A	EC-314992	C STY V F05 CQF09 681J 50DC
2-C64	EC-314993	C STY V SNP CQFS 751J 50DC
2-C69A	EC-314990	C STY V SNP CQFS 101J 50DC
2-C79A	EC-321482	C STY V F05 500 271J 50DC
<b>JACK P.C BOARD</b>		
2-J1B	EJ-345812	PHONE J HLJ0527-714 2P×2
2-J2B	EJ-344640	PHONE J 2P HLJ4308-034 6.3 1T

## 3. SYSCON P.C BOARD BLOCK

REF. NO.	PARTS NO.	DESCRIPTION
3-1	BA-T2045A180A	PC SYSCON BLK HX-R5
<b>SYSCON P.C BOARD</b>		
3-IC1A	EI-345758	IC LM6402H-155
3-IC2A, 3A	EI-337008	IC LC7800
3-IC4A	EI-345759	IC LC7530
3-IC5A	EI-330352	IC BA6109
3-IC6A	EI-337013	IC LBI290
3-IC7A to 9A	EI-337009	IC LC4049B
3-TR1A	ET-200505	TR 2SC2603 E,F
3-TR2A, 3A	ET-200558	TR 2SA1115 E,F
3-TR4A	ET-346298	TR 2SA1246 S,T
3-TR5A to 7A	ET-200558	TR 2SA1115 E,F
3-TR8A to 10A	ET-200505	TR 2SC2603 E,F
3-TR11A	ET-200558	TR 2SA1115 E,F
3-TR12A, 13A	ET-200505	TR 2SC2603 E,F
3-TR14A	ET-200558	TR 2SA1115 E,F
3-D1A to 4A	ED-337575	D SILICON H GMA-01-4-BT T26
3-D5A	ED-560913	D SILICON V 1S2473VE
3-D6A	ED-345820	D ZENER V HZ9B-2S1
3-D7A	ED-337575	D SILICON H GMA-01-4-BT T26
3-D8A	ED-345821	D ZENER V HZ7A-1S1
3-D9A	ED-337575	D SILICON H GMA-01-4-BT T26
3-D10A	ED-338454	D ZENER V HZ9C-2S1
3-D11A	ED-337575	D SILICON H GMA-01-4-BT T26
3-VR1A	EV-522652	R S-FIX V V8K1-1 3P 105
3-CR1A	EC-345808	C COMP 05-0047
3-CR2A	ER-344278	R COMP 01-0371
3-CR3A	ER-345757	R COMP 01-0517
3-X1A	EI-337017	OSC CE CSB800A 0.800000MC
<b>METER P.C BOARD</b>		
3-IC1B	EI-337845	IC BA6146 M
3-IC2B to 4B	EI-337013	IC LBI290
3-SW1B to 15B	ES-336780	SW TACT KHH10902
3-SW16B, 17B	ES-337843	SW PUSH ESB-64501 02-2
3-SW19B	ES-345838	SW SLIDE 00230745 2-02-03N
3-IN1B	EM-345810	IND FL FIP48AW16Y DOUBLE

## 4. POWER SUPPLY P.C BOARD BLOCK

REF. NO.	PARTS NO.	DESCRIPTION
4-TR1	ET-200558	TR 2SA1115 E,F
4-TR2	ET-200505	TR 2SC2603 E,F
4-TR3	ET-200558	TR 2SA1115 E,F
4-TR4	ET-310148	△ TR 2SD612K E,F
4-TR5	ET-200505	TR 2SC2603 E,F
4-TR6	ET-310148	△ TR 2SD612K E,F
4-TR7	ET-200505	TR 2SC2603 E,F
4-D1	ED-337575	D SILICON H GMA-01-4-BT T26
4-D2	ED-338013	D ZENER V HZ24-3S1
4-D3	ED-337575	D SILICON H GMA-01-4-BT T26
4-D4	ED-336998	D ZENER V HZ6B-2S1
4-D5	ED-330319	△ D SILICON DBA10B 100/1.0A
4-D6	ED-306109	D SILICON W03B 100/1.0A
4-D7	ED-345822	D ZENER V HZ6C-3S1
4-D8	ED-330319	△ D SILICON DBA10B 100/1.0A
4-D9	ED-337868	D ZENER V HZ20-3S1
4-D10	ED-345822	D ZENER V HZ6C-3S1
4-D11	ED-337868	D ZENER V HZ20-3S1
4-SW1	ES-344270	△ SW PUSH SDLD1P 01-1
4-R10	ER-333654	R CB H S15 FS RDS 1/2W 332J
4-C1U	EC-338396	△ C MMY V ECQEW 473M 250AC (U)
4-C1C	EC-320548	△ C CE V F 103Z 250AC (C,A)
4-C1E	EC-338411	△ C CE V FZ 103P 400AC (J)
4-C1J	EC-338396	△ C MMY V ECQEW 473M 250AC (E,V,B,S)
4-C5, C6	EC-201761	C EC V CUT USM 472M 16.0DC

ASSEMBLY BLOCK

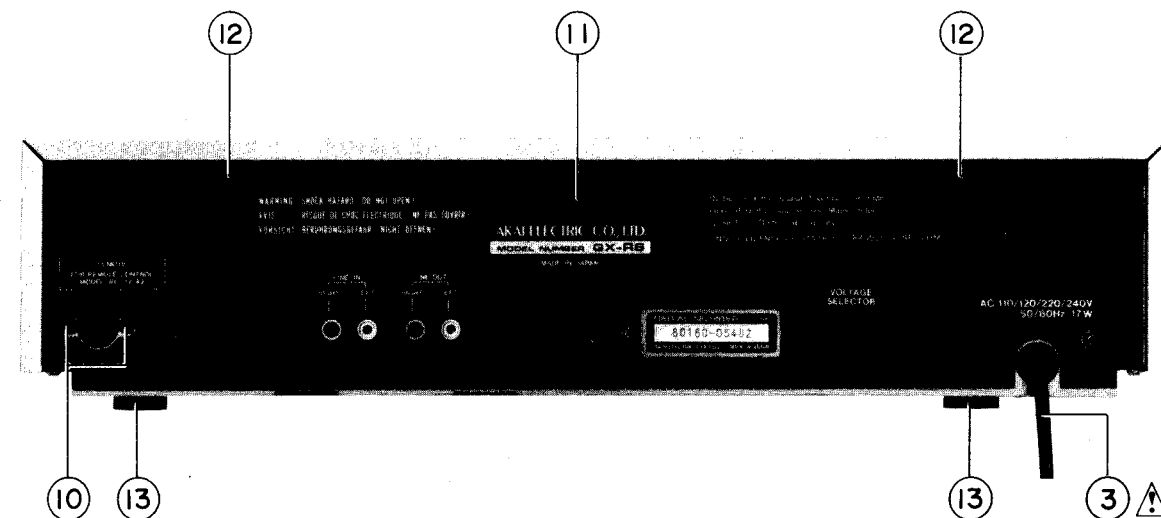
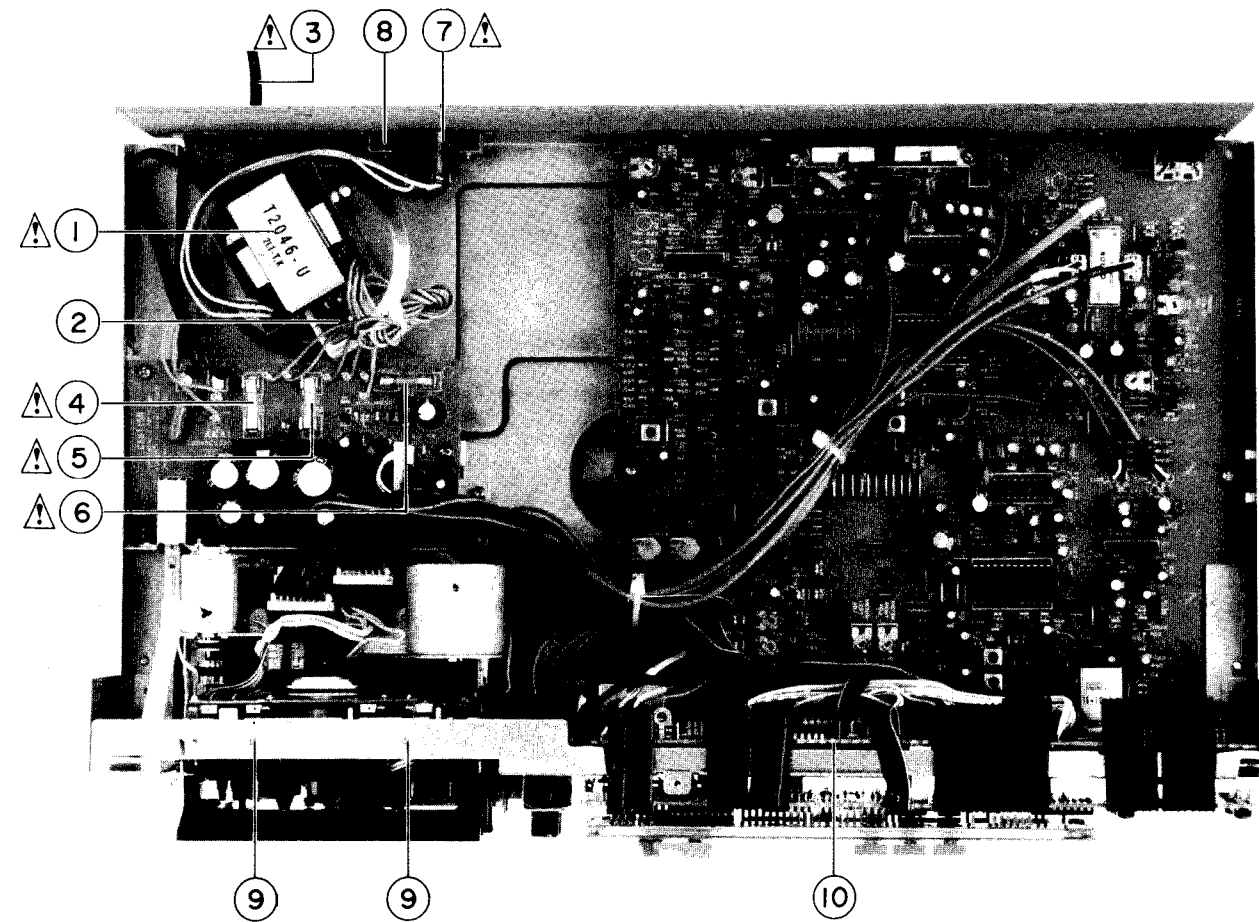

5. ASSEMBLY BLOCK

REF. NO.	PARTS NO.	DESCRIPTION
5-1U	BT-345831	⚠ TRANS POWER T2045 (U) (T901)
5-1J	BT-345832	⚠ TRANS POWER T2045 (J) (T901)
5-1C	BT-345833	⚠ TRANS POWER T2045 (C.A) (T901)
5-1E	BT-345834	⚠ TRANS POWER T2045 (E.V) (T901)
5-1B	BT-345835	⚠ TRANS POWER T2045 (B.S) (T901)
5-2	ZS-314702	ST BID40×10STL CMT
5-3U	EW-347601	⚠ AC CORD 2 CORES KP-205A VFF J (U)
5-3J	EW-347836	⚠ AC CORD 2 CORES KP-209A VFF J (J)
5-3C	EW-348215	⚠ AC CORD 2 CORES KP10.SPT-1 105C UC (C.A)
5-3E	EW-347602	⚠ AC CORD 2 CORES (E)(E.V)
5-3B	EW-347679	⚠ AC CORD LTBS-2F 42/0.15×2 (B)
5-3S	EW-347603	⚠ AC CORD 2 CORES (S)(S)
5-4U	EF-306124	⚠ FUSE TSC A 250V 0.63A (F1)(U.J)
5-4C	EF-305703	⚠ FUSE TSC 125V 0.63A (F1)(C.A)
5-4E	EF-601942	⚠ FUSE SEMKO T 250V 0.63A (F1)(E.V.B.S)
5-5U	EF-306124	⚠ FUSE TSC A 250V 0.63A (F2)(U.J)
5-5C	EF-305703	⚠ FUSE TSC 125V 0.63A (F2)(C.A)
5-5E	EF-601942	⚠ FUSE SEMKO T 250V 0.63A (F2)(E.V.B.S)
5-6U	EF-309389	⚠ FUSE TSC A 250V 0.40A (F3)(U.J)
5-6C	EF-308848	⚠ FUSE TSC 125V 0.40A (F3)(C.A)
5-6E	EF-668474	⚠ FUSE SEMKO T 250V 0.40A (F3)(E.V.B.S)
5-7	ES-305733	⚠ SW SELECTOR HXW0131-260 01-4 (VS901) (U ONLY)
5-8	ZS-320906	ST BR30×06STL CMT (U ONLY)
5-9	ZS-337783	PT CTS30×08STL CMT
5-10	ZW-698308	RV NYL30×055 BL
5-11U	SP-344592A	PANEL REAR GX-R6 (U)
5-11J	SP-344592B	PANEL REAR GX-R6 (J)
5-11C	SP-344592C	PANEL REAR GX-R6 (C)
5-11E	SP-344592D	PANEL REAR GX-R6 (A)
5-11V	SP-344592E	PANEL REAR GX-R6 (E.V)
5-11B	SP-344592F	PANEL REAR GX-R6 (B.S)
5-12	ZS-346048	T2BR30×08STL BNI C080
5-13	SA-343007	FOOT
5-14x	ZW-305013	RV POP32 (A ONLY)

**FINAL ASSEMBLY BLOCK**

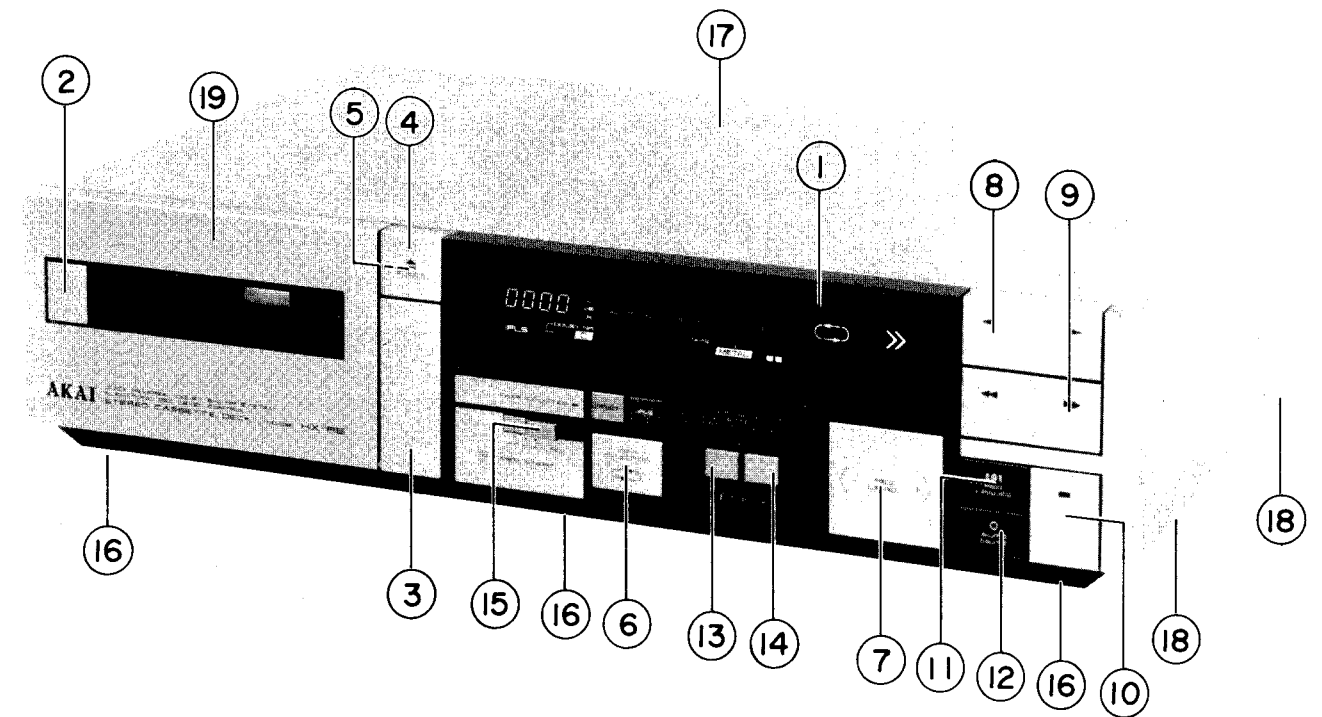

**6. FINAL ASSEMBLY BLOCK**

REF. NO.	PARTS NO.	DESCRIPTION
6-1	BD-T2045A200A	PANEL FRONT BLK HX-R5
6-1P	BD-T2045A200B	PANEL FRONT BLK HX-R5-P
<b>PANEL FRONT BLOCK</b>		
6-2	SK-343017A	KNOB POWER
6-2P	SK-343017B	KNOB POWER-P
6-3	BD-344577A	PANEL DOOR
6-3P	SP-344577B	PANEL DOOR P
6-4	SK-344578A	KNOB (A)
6-4P	SK-344578B	KNOB (A) P
6-5	ZG-344749	SP PUSH KNOB (A)
6-6	SK-344581A	KNOB (D)
6-6P	SK-344581B	KNOB (D) P
6-7	SK-344583A	KNOB (F)
6-7P	SK-344583B	KNOB (F) P
6-8	SK-344587C	KNOB OPERATE (A-2)
6-8P	SK-344587B	KNOB OPERATE (A-1) P
6-9	SK-344589C	KNOB OPERATE (B-2)
6-9P	SK-344589B	KNOB OPERATE (B-1) P
6-10	SK-344590C	KNOB OPERATE (C-2)
6-10P	SK-344590B	KNOB OPERATE (C-1) P
6-11	SK-343014B	KNOB OPERATE (E)
6-12	SK-343014D	KNOB OPERATE (F)

<b>FINAL ASSEMBLY BLOCK</b>		
6-13	SK-344584A	KNOB PUSH (A)
6-13P	SK-344584B	KNOB PUSH (A) P
6-14	SK-344584C	KNOB PUSH (B)
6-14P	SK-344584D	KNOB PUSH (B) P
6-15	SK-344585A	KNOB SLIDE
6-15P	SK-344585B	KNOB SLIDE P
6-16	ZS-331567	T2BR30x08STL CMT C080
6-17	SP-344591A	COVER UPPER
6-17P	SP-344591B	COVER UPPER P
6-18	ZS-455207	T2BR30x05STL CMT
6-19	BD-B344571A	LID PANEL PART
6-19P	BD-B344571B	LID PANEL-P PART

SYMBOL FOR COLOR VARIATION  
 NONE - SILVER  
 P - PEARL SHADOW

## II. MODEL GX-R6

GX-R6

### RECOMMENDED SPARE PARTS

Because, if the parts listed below are on hand, almost any repair can be accomplished, we suggest that you stock these Recommended Spare Parts Items.

REF. NO.	PARTS NO.	DESCRIPTION
1	BF-344029	FLYWHEEL
2	BH-T2045A030B	HEAD BLK GX-R6
3	BL-T2045A050A	ARM PINCH ROLLER (L) BLK HX-R5
4	BL-T2045A060A	ARM PINCH ROLLER (R) BLK HX-R5
5	BM-B604491	MOTOR (PULLEY) PART EG-510ED 2B2
6	BM-B604490	MOTOR OPERATION (PULLEY) PART
7	BR-344098	REEL TABLE (A) ASSY
8	BT-348946	△ TRANS POWER T2046 (A,C) (T901)
9	BT-347805	△ TRANS POWER T2046 (B,S) (T901)
10	BT-347804	△ TRANS POWER T2046 (E,V) (T901)
11	BT-348945	△ TRANS POWER T2046 (J) (T901)
12	BT-347803	△ TRANS POWER T2046 (U) (T901)
13	BZ-T2045A040A	GUIDE DETECTION BLK HX-R5
14	EC-345808	C COMP 05-0047
15	ED-330319	△ D SILICON DBA 10B 100/1.0A
16	ED-310340	D LED GL-350 INFRARED RAY (D902)
17	ED-301911	D SILICON H DS448
18	ED-337575	D SILICON H GMA-01-4-BT T26
19	ED-560913	D SILICON V 1S2473VE
20	ED-306109	D SILICON W03B 100/1.0A
21	ED-305704	D ZENER H HZ4 B2
22	ED-337868	D ZENER V HZ20-3S1
23	ED-338013	D ZENER V HZ24-3S1
24	ED-336998	D ZENER V HZ6B-2S1
25	ED-345822	D ZENER V HZ6C-3S1
26	ED-345821	D ZENER V HZ7A-1S1
27	ED-345820	D ZENER V HZ9B-2S1
28	ED-338454	D ZENER V HZ9C-2S1
29	EF-668474	△ FUSE SEMKO T 250V 0.40A (F3) (E,V,B,S)
30	EF-601942	△ FUSE SEMKO T 250V 0.63A (F2) (E,V,B,S)
31	EF-601942	△ FUSE SEMKO T 250V 0.63A (F1) (E,V,B,S)
32	EF-309389	△ FUSE TSC A 250V 0.40A (F3) (U,J)
33	EF-306124	△ FUSE TSC A 250V 0.63A (F1) (U,J)
34	EF-306124	△ FUSE TSC A 250V 0.63A (F2) (U,J)
35	EF-308848	△ FUSE TSC 125V 0.40A (F3) (C,A)
36	EF-305703	△ FUSE TSC 125V 0.63A (F1) (C,A)
37	EF-305703	△ FUSE TSC 125V 0.63A (F2) (C,A)
38	EI-330352	IC BA6109
39	EI-337845	IC BA6146 M
40	EI-336761	IC LA6458S
41	EI-337013	IC LB1290
42	EI-337009	IC LC4049B
43	EI-345759	IC LC7530
44	EI-337008	IC LC7800
45	EI-348465	IC LM6402H-190
46	EI-337228	IC M5218L0
47	EI-337835	IC NE652
48	EI-344291	IC NE654
49	EI-337017	OSC CE CSB800A 0.800000MC
50	EJ-346076	DIN J TCS4690-01-1111 P 8P
51	EJ-345812	PHONE J Hlj0527-714 2P×2
52	EJ-344640	PHONE J 2P Hlj4308-034 6.3 1T
53	EJ-347664	PIN J YKC21-5053 P 4P
54	EL-348214	PL LEAD 28.0V 24MA (IN1)
55	EM-345810	IND FL FIP48AW16Y DOUBLE
56	EO-669273	COIL FIX 2 FL5R200 18μH
57	EO-337044	COIL FIX 2 102AK-005 36MH
58	EO-345836	COIL OSC 1 32-5008-12 100 KHz
59	EO-315758	COIL TUN 1 100S-431 100.00 KC
60	EO-337055	COIL VARI 1 FE002S 10 MH
61	EP-337067	RELAY LEAD LAB2NS 2NO 18V
62	ER-318248	△ R FUSE ERD2FC S10 1/4W 47R0G
63	ER-337695	FILTER DB 201AK-005 100 KC
64	ER-337696	FILTER DB 201AK-006 19 KHz
65	ER-344278	R COMP 01-0371
66	ER-345757	R COMP 01-0517
67	ES-344270	△ SW PUSH SDDL1P 01-1 (VS901)(U ONLY)
68	ES-305733	△ SW SELECTOR HXW0131-260 01-4 (VS901)(U ONLY)
69	ES-344104	SW LEAF BSW-191 01-1 NO (SW901)
70	ES-344101	SW LEAF MD-1003 01-1 NO (SW905)
71	ES-336814	SW LEAF MSW-1150NBK 01-1 NO (SW902)
72	ES-344253	SW LEAF MSW-1418J 01-1 NO (SW904)
73	ES-344257	SW LEAF MSW-1418L 01-1 NO (SW903)
74	ES-337843	SW PUSH ESB-64501 02-2
75	ES-345838	SW SLIDE 00230745 2-02-03N
76	ES-336780	SW TACT KHH10902
77	ET-310148	△ TR 2SD612K E, F
78	ET-311977	PHOTO SENSOR SPI-201 (PH1)
79	ET-310341	TR PHOTO RT350 T (TR92)
80	ET-344102	TR PHOTO GP-1S04 (PH2)
81	ET-200558	TR 2SA1115 E, F
82	ET-346298	TR 2SA1246 S, T
83	ET-330607	TR 2SC1312S F, G
84	ET-337258	TR 2SC1843 E, F
85	ET-309353	TR 2SC2274K E, F
86	ET-328578	TR 2SC2320 E, F
87	ET-200505	TR 2SC2603 E, F
88	ET-328868	TR 2SD1012-V G, H
89	ET-307349	TR 2SD794 P, Q
90	EV-345610	R S-FIX H H0811C307A 3P 102
91	EV-342939	R S-FIX H H0811C313A 3P 103
92	EV-345611	R S-FIX H H0811C343A 3P 502
93	EV-342940	R S-FIX H H0811C344A 3P 203
94	EV-342942	R S-FIX H H0811C345A 3P 503
95	EV-338467	R S-FIX H TM8K 3P 0.30W 104
96	EV-522652	R S-FIX V V8K1-1 3P 105
97	EV-337841	VR SLIDE 30P2SV0A B103
98	HR-H2501A010A	HEAD COMB EPR4-9
99	MB-344088	BELT CAM
100	MB-344041	BELT CAPSTAN
101	MB-344042	BELT WIND (A)
102	MB-344043	BELT WIND (B)
103	MB-344028	PULLEY RUBBER
104	MI-344095	IDLER PLAY (L) ASSY
105	MI-344094	IDLER PLAY (R) ASSY





**2. PRE-AMP P.C BOARD BLOCK**

REF. NO.	PARTS NO.	DESCRIPTION
2-1	BA-T2046A020A	PC PRE-AMP BLK GX-R6
<b>PRE-AMP P.C BOARD</b>		
2-IC1A	EI-337228	IC M5218L0
2-IC2A	EI-344291	IC NE654
2-IC3A	EI-337835	IC NE652
2-IC4A, 5A	EI-336761	IC LA6458S
2-IC6A	EI-337228	IC M5218L0
2-TR1A to 4A	ET-328578	TR 2SC2320 E,F
2-TR5A	ET-307349	TR 2SD794 P,Q
2-TR6A	ET-328868	TR 2SD1012-V G,H
2-TR8A to 13A	ET-328578	TR 2SC2320 E,F
2-TR14A	ET-309353	TR 2SC2274K E,F
2-TR15A, 16A	ET-200505	TR 2SC2603 E,F
2-TR18A, 19A	ET-200505	TR 2SC2603 E,F
2-TR20A, 21A	ET-309353	TR 2SC2274K E,F
2-TR22A, 23A	ET-200505	TR 2SC2603 E,F
2-TR24A, 25A	ET-328578	TR 2SC2320 E,F
2-TR26A	ET-337258	TR 2SC1843 E,F
2-TR27A	ET-330607	TR 2SC1312S F,G
2-TR28A	ET-328578	TR 2SC2320 E,F
2-TR29A, 32A	ET-200505	TR 2SC2603 E,F
2-D1A	ED-305704	D ZENER H HZ4 B2
2-D4A	ED-337575	D SILICON H GMA-01-4-BT T26
2-D5A to 9A	ED-301911	D SILICON H DS448
2-D10A	ED-337575	D SILICON H GMA-01-4-BT T26
2-D11A to 13A	ED-301911	D SILICON H DS448
2-VR1A	EV-342940	R S-FIX H H0811C344A 3P 203
2-VR2A	EV-345610	R S-FIX H H0811C307A 3P 102
2-VR3A	EV-345611	R S-FIX H H0811C343A 3P 502
2-VR4A	EV-342939	R S-FIX H H0811C313A 3P 103
2-VR5A, 6A	EV-342942	R S-FIX H H0811C345A 3P 503
2-VR7A	EV-338467	R S-FIX H TM8K 3P 0.30W 104
2-RL1A	EP-337067	RELAY LEAD LAB2NS 2NO 18V
2-T1A	EO-345836	COIL OSC 1 32-5008-12 100kHz
2-VL1A	EO-337055	COIL VARI 1 FE002S 10MH
2-L1A	EO-669273	COIL FIX 2 FL5R200 18μH
2-FL1A	ER-337695	FILTER DB 201AK-005 100KC
2-FL2A	ER-337696	FILTER DB 201AK-006 19kHz
2-FL3A	EO-337044	COIL FIX 2 102AK-005 36MH
2-FL4A	EO-315758	COIL TUN 1 100S-431 100.00KC
2-J1A	EJ-347664	PIN J YKC21-5053 P 4P
2-J2A	EJ-346076	DIN J TCS4690-01-1111 P 8P
2-FR3A	ER-318248	△ R FUSE ERD2FC S10 1/4W 47R0G
2-R4A	ER-326616	R OMF H SNP FS 1W 681J
2-C57A	EC-335306	C STY V F05 CQ09S 162J 250DC
2-C61A	EC-314992	C STY V F05 CQF09 681J 50DC
2-C69A	EC-310440	C STY V F05 CQF09 471J 50DC
2-C79A	EC-321482	C STY V F05 500 271J 50DC
2-C85A	EC-314992	C STY V F05 CQF09 681J 50DC

**JACK P.C BOARD**

2-J1B	EJ-345812	PHONE J HLJ0527-714 2P×2
2-J2B	EJ-344640	PHONE J 2P HLJ4308-034 6.3 1T

**OUTPUT P.C BOARD**

2-VR1C	EV-337841	VR SLIDE 30P2SVOA B103
--------	-----------	------------------------

**3. SYSCON P.C BOARD BLOCK**

REF. NO.	PARTS NO.	DESCRIPTION
3-1	BA-T2046A030A	PC SYSCON BLK GX-R6
<b>SYSCON P.C BOARD</b>		
3-IC1A	EI-348465	IC LM6402H-190
3-IC2A, 3A	EI-337008	IC LC7800
3-IC4A	EI-345759	IC LC7530
3-IC5A	EI-330352	IC BA6109
3-IC6A	EI-337013	IC LB1290
3-IC7A to 9A	EI-337009	IC LC4049B
3-TR1A	ET-200505	TR 2SC2603 E,F
3-TR2A, 3A	ET-200558	TR 2SA1115 E,F
3-TR4A	ET-346298	TR 2SA1246 S,T
3-TR5A to 7A	ET-200558	TR 2SA1115 E,F
3-TR8A to 10A	ET-200505	TR 2SC2603 E,F
3-TR11A	ET-200558	TR 2SA1115 E,F
3-TR12A, 13A	ET-200505	TR 2SC2603 E,F
3-TR14A	ET-200558	TR 2SA1115 E,F
3-D1A to 4A	ED-337575	D SILICON H GMA-01-4-BT T26
3-D5A	ED-560913	D SILICON V 1S2473VE
3-D6A	ED-345820	D ZENER V HZ9B-2S1
3-D7A	ED-337575	D SILICON H GMA-01-4-BT T26
3-D8A	ED-345821	D ZENER V HZ7A-1S1
3-D9A	ED-337575	D SILICON H GMA-01-4-BT T26
3-D10A	ED-338454	D ZENER V HZ9C-2S1
3-D11A	ED-337575	D SILICON H GMA-01-4-BT T26
3-VR1A	EV-522652	R S-FIX V V8K1-1 3P 105
3-CR1A	EC-345808	C COMP 05-0047
3-CR2A	ER-344278	R COMP 01-0371
3-CR3A	ER-345757	R COMP 01-0517
3-X1A	EI-337017	OSC CE CSB800A 0.800000MC

**METER P.C BOARD**

3-IC1B	EI-337845	IC BA6146 M
3-IC2B to 4B	EI-337013	IC LB1290
3-SW1B to 15B	ES-336780	SW TACT KHH10902
3-SW16B to 18B	ES-337843	SW PUSH ESB-64501 02-2
3-SW19B	ES-345838	SW SLIDE 00230745 2-02-03N
3-IN1B	EM-345810	IND FL FIP48AW16Y DOUBLE

**4. POWER SUPPLY P.C BOARD BLOCK**

REF. NO.	PARTS NO.	DESCRIPTION
4-TR1	ET-200558	TR 2SA1115 E,F
4-TR2	ET-200505	TR 2SC2603 E,F
4-TR3	ET-200558	TR 2SA1115 E,F
4-TR4	ET-310148	△ TR 2SD612K E,F
4-TR5	ET-200505	TR 2SC2603 E,F
4-TR6	ET-310148	△ TR 2SD612K E,F
4-TR7	ET-200505	TR 2SC2603 E,F
4-D1	ED-337575	D SILICON H GMA-01-4-BT T26
4-D2	ED-338013	D ZENER V HZ24-3S1
4-D3	ED-337575	D SILICON H GMA-01-4-BT T26
4-D4	ED-336998	D ZENER V HZ6B-2S1
4-D5	ED-330319	△ D SILICON DBA10B 100/1.0A
4-D6	ED-306109	D SILICON W03B 100/1.0A
4-D7	ED-345822	D ZENER V HZ6C-3S1
4-D8	ED-330319	△ D SILICON DBA10B 100/1.0A
4-D9	ED-337868	D ZENER V HZ20-3S1
4-D10	ED-345822	D ZENER V HZ6C-3S1
4-D11	ED-337868	D ZENER V HZ20-3S1
4-SW1	ES-344270	△ SW PUSH SDDL1P 01-1
4-R10	ER-333654	R CB H S15 FS RDS 1/2W 332J
4-C1U	EC-338396	△ C MMY V ECQEW 473M 250AC (U)
4-C1C	EC-320548	△ C CE V F 103Z 250AC (C,A)
4-C1E	EC-338411	△ C CE V FZ 103P 400AC (J)
4-C1J	EC-338396	△ C MMY V ECQEW 473M 250AC (E,V,B,S)
4-C5, C6	EC-201761	C EC V CUT USM 472M 16.0DC



ASSEMBLY BLOCK

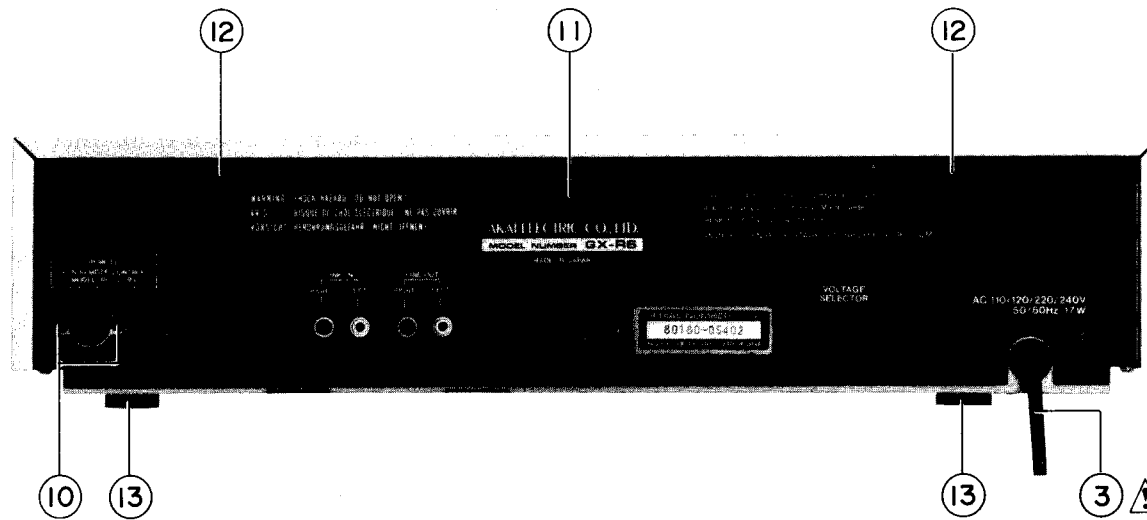
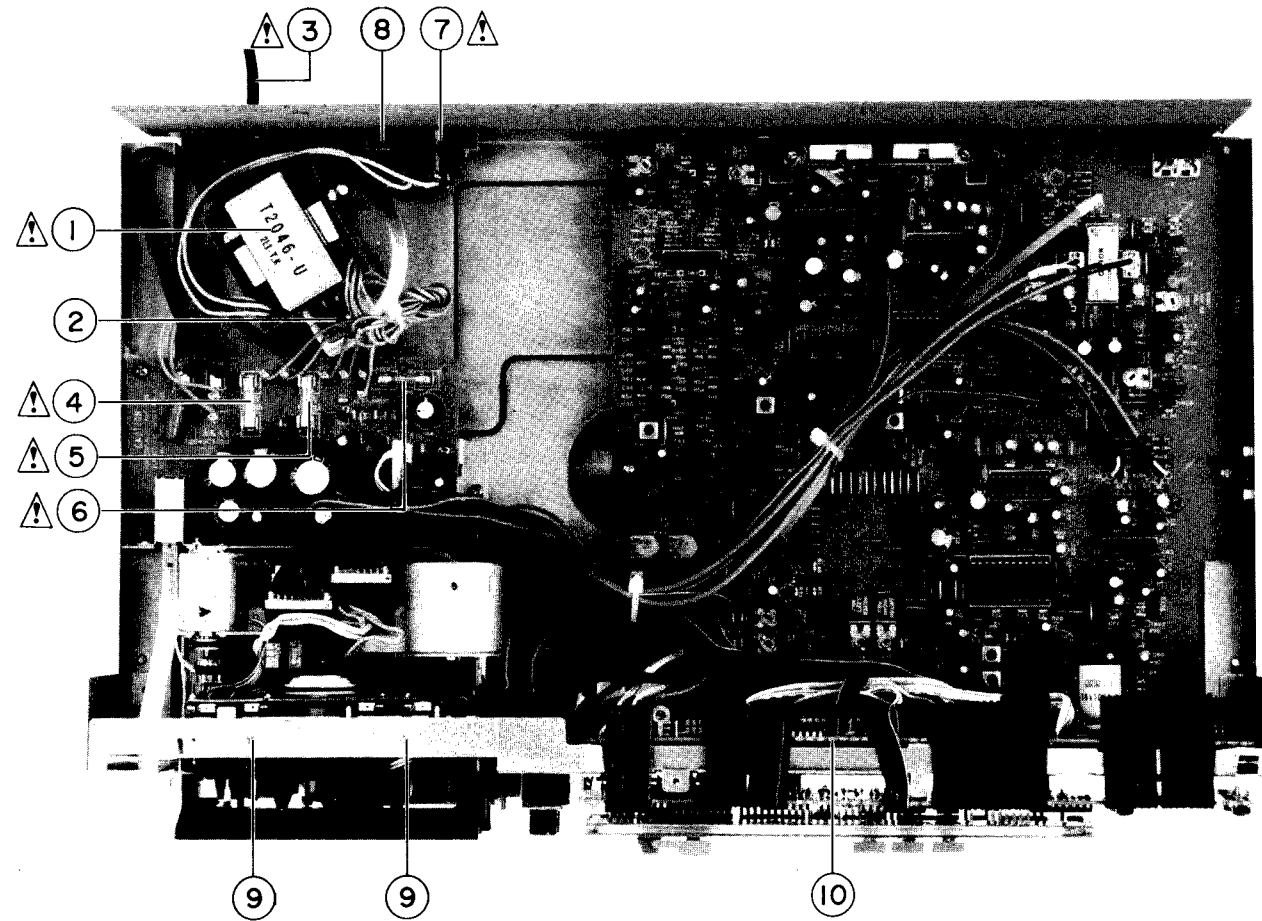

5. ASSEMBLY BLOCK

REF. NO.	PARTS NO.	DESCRIPTION
5-1U	BT-347803	⚠ TRANS POWER T2046 (U) (T901)
5-1J	BT-348945	⚠ TRANS POWER T2046 (J) (T901)
5-1C	BT-348946	⚠ TRANS POWER T2046 (A.C) (T901)
5-1E	BT-347804	⚠ TRANS POWER T2046 (E.V) (T901)
5-1B	BT-347805	⚠ TRANS POWER T2046 (B.S) (T901)
5-2	ZS-314702	ST BID40×10STL CMT
5-3U	EW-347601	⚠ AC CORD 2 CORES KP-205A VFF J (U)
5-3J	EW-347836	⚠ AC CORD 2 CORES KP-209 VFF J (J)
5-3C	EW-348215	⚠ AC CORD 2 CORES KP10.SPT-1 105C UC (C.A)
5-3E	EW-347602	⚠ AC CORD 2 CORES (E) (E.V)
5-3B	EW-347679	⚠ AC CORD LTBS-2F 42/0.15×2 (B)
5-3S	EW-347603	⚠ AC CORD 2 CORES (S) (S)
5-4U	EF-306124	⚠ FUSE TSC A 250V 0.63A (F1)(U.J)
5-4C	EF-305703	⚠ FUSE TSC 125V 0.63A (F1)(C.A)
5-4E	EF-601942	⚠ FUSE SEMKO T 250V 0.63A (F1)(E.V.B.S)
5-5U	EF-306124	⚠ FUSE TSC A 250V 0.63A (F2)(U.J)
5-5C	EF-305703	⚠ FUSE TSC 125V 0.63A (F2)(C.A)
5-5E	EF-601942	⚠ FUSE SEMKO T 250V 0.63A (F2)(E.V.B.S)
5-6U	EF-309389	⚠ FUSE TSC A 250V 0.40A (F3)(U.J)
5-6C	EF-308848	⚠ FUSE TSC 125V 0.40A (F3)(C.A)
5-6E	EF-668474	⚠ FUSE SEMKO T 250V 0.40A (F3)(E.V.B.S)
5-7	ES-305733	⚠ SW SELECTOR HXW0131-260 01-4 (VS901) (U ONLY)
5-8	ZS-320906	ST BR30×06STL CMT (U ONLY)
5-9	ZS-337783	PT CTS30×08STL CMT
5-10	ZW-698308	RV MYL30×055 BL
5-11U	SP-344592A	PANEL REAR GX-R6 (U)
5-11J	SP-344592B	PANEL REAR GX-R6 (J)
5-11C	SP-344592C	PANEL REAR GX-R6 (C)
5-11E	SP-344592D	PANEL REAR GX-R6 (A)
5-11V	SP-344592E	PANEL REAR GX-R6 (E.V)
5-11B	SP-344592	PANEL REAR GX-R6 (B.S)
5-12	ZS-346048	T2BR30×08STL BNI C080
5-13	SA-343007	FOOT
5-14x	ZW-305013	RV POP32 (A ONLY)

**FINAL ASSEMBLY BLOCK**

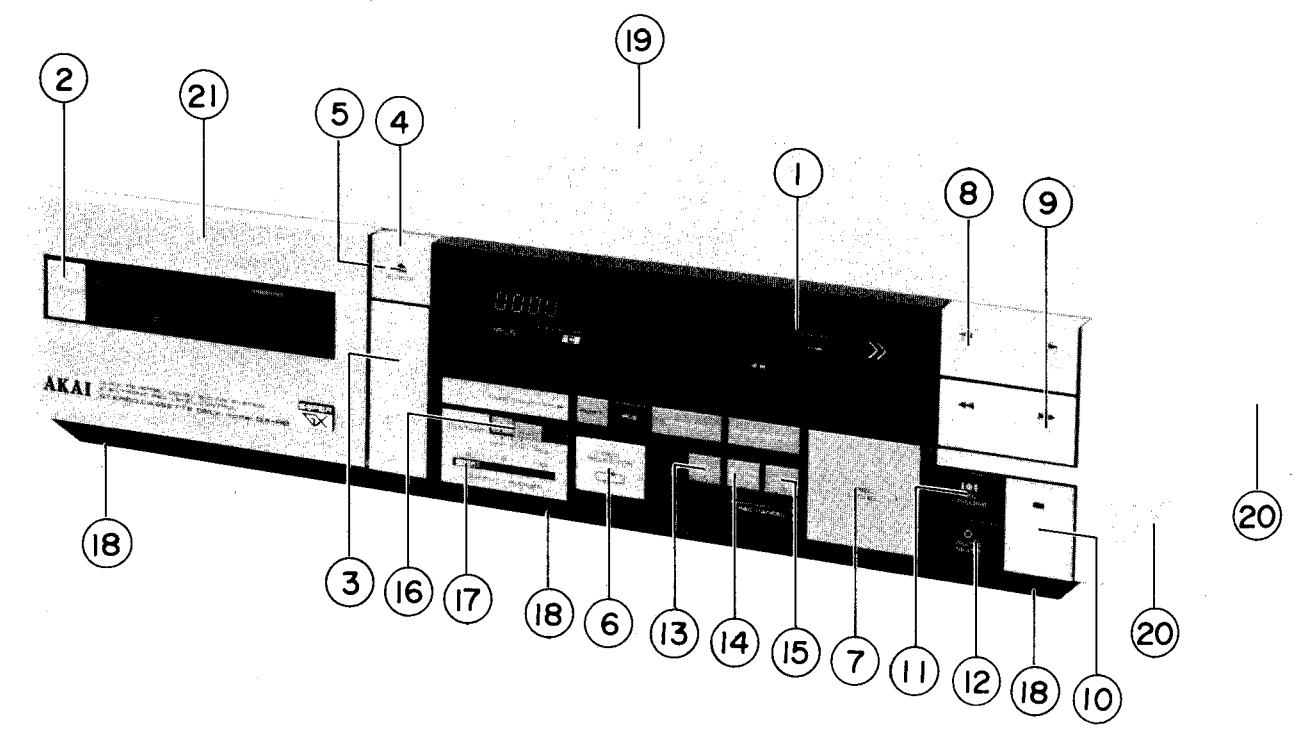

**6. FINAL ASSEMBLY BLOCK**

REF. NO.	PARTS NO.	DESCRIPTION
6-1	BD-T2046A050A	PANEL FRONT BLK GX-R6
6-1P	BD-T2046A050B	PANEL FRONT BLK GX-R6-P
<b>PANEL FRONT BLOCK</b>		
6-2	SK-343017A	KNOB POWER
6-2P	SK-343017B	KNOB POWER-P
6-3	BD-344577A	PANEL DOOR
6-3P	SP-344577B	PANEL DOOR P
6-4	SK-344578A	KNOB (A)
6-4P	SK-344578B	KNOB (A) P
6-5	ZG-344749	SP PUSH KNOB (A)
6-6	SK-344581A	KNOB (D)
6-6P	SK-344581B	KNOB (D) P
6-7	SK-344583A	KNOB (F)
6-7P	SK-344583B	KNOB (F) P
6-8	SK-344587C	KNOB OPERATE (A-2)
6-8P	SK-344587B	KNOB OPERATE (A-1) P
6-9	SK-344589C	KNOB OPERATE (B-2)
6-9P	SK-344589B	KNOB OPERATE (B-1) P
6-10	SK-344590C	KNOB OPERATE (C-2)
6-10P	SK-344590B	KNOB OPERATE (C-1) P
6-11	SK-343014B	KNOB OPERATE (E)
6-12	SK-343014D	KNOB OPERATE (F)

<b>FINAL ASSEMBLY BLOCK</b>		
6-13	SK-344584A	KNOB PUSH (A)
6-13P	SK-344584B	KNOB PUSH (A) P
6-14	SK-344584C	KNOB PUSH (B)
6-14P	SK-344584D	KNOB PUSH (B) P
6-15	SK-344584E	KNOB PUSH (C)
6-15P	SK-344584F	KNOB PUSH (C) P
6-16	SK-344585A	KNOB SLIDE
6-16P	SK-344585B	KNOB SLIDE P
6-17	SK-343009	KNOB OUTPUT
6-17P	SK-343009B	KNOB OUTPUT-P
6-18	ZS-331567	T2BR30x08STL CMT C080
6-19	SP-344591A	COVER UPPER
6-19P	SP-344591B	COVER UPPER P
6-20	ZS-455207	T2BR30x05STL CMT
6-21	BD-B343023C	LID PANEL (2) PART
6-21P	BD-B343023D	LID PANEL (2) P PART

**SYMBOL FOR COLOR VARIATION**  
 NONE - SILVER  
 P - PEARL SHADOW

# INDEX

## 1. HX-R5

PARTS NO.	REF. NO.	PARTS NO.	REF. NO.	PARTS NO.	REF. NO.	PARTS NO.	REF. NO.
BA-T2045A170A	2-1	EI-337008	3-IC3A	ET-200558	3-TR5A	MZ-344036	1-47
BA-T2045A180A	3-1	EI-337008	3-IC2A	ET-200558	3-TR6A	MZ-344039	1-44
BD-B344049A1	1-79	EI-337009	3-IC9A	ET-200558	3-TR7A	MZ-344083	1-108
BD-B344571A	6-19	EI-337009	3-IC8A	ET-200558	3-TR2A	MZ-344099	1-70
BD-B344571B	6-19P	EI-337009	3-IC7A	ET-200558	3-TR3A	SA-343007	5-13
BD-T2045A200A	6-1	EI-337013	3-IC6A	ET-200558	4-TR3	SK-343014B	6-11
BD-T2045A200B	6-1P	EI-337013	3-IC2B	ET-200558	4-TR1	SK-343014D	6-12
BD-344577A	6-3	EI-337013	3-IC4B	ET-307349	2-TR5A	SK-343017A	6-2
BF-344029	1-64	EI-337013	3-IC3B	ET-309353	2-TR21A	SK-343017B	6-2P
BH-T2045A030A	1-2	EI-337017	3-X1A	ET-309353	2-TR20A	SK-344578A	6-4
BL-T2045A050A	1-80	EI-337228	2-IC1A	ET-309353	2-TR14A	SK-344578B	6-4P
BL-T2045A060A	1-81	EI-337835	2-IC3A	ET-310148	4-TR6	SK-344581A	6-6
BM-B604490	1-105	EI-33845	3-IC1B	ET-310148	4-TR4	SK-344581B	6-6P
BM-B604491	1-109	EI-344291	2-IC2A	ET-310341	1-85	SK-344583A	6-7
BR-344098	1-57	EI-345758	3-IC1A	ET-311977	1-84	SK-344583B	6-7P
BT-345831	5-1U	EI-345759	3-IC4A	ET-328578	2-TR12A	SK-344584A	6-13
BT-345832	5-1J	EJ-344640	2-J2B	ET-328578	2-TR4A	SK-344584B	6-13P
BT-345833	5-1C	EJ-345812	2-J1B	ET-328578	2-TR1A	SK-344584C	6-14
BT-345834	5-1E	EJ-346076	2-J2A	ET-328578	2-TR3A	SK-344584D	6-14P
BT-345835	5-1B	EJ-347664	2-J1A	ET-328578	2-TR25A	SK-344585A	6-15
BZ-T2045A020A	1-1	EL-348214	1-113	ET-328578	2-TR28A	SK-344585B	6-15P
BZ-T2045A040A	1-28	EM-345810	3-IN1B	ET-328578	2-TR13A	SK-344587B	6-8P
EA-343156	1-7	EO-315758	2-FL4A	ET-328578	2-TR11A	SK-344587C	6-8
EC-201761	4-C6	EO-337044	2-FL3A	ET-328578	2-TR10A	SK-344589B	6-9P
EC-201761	4-C5	EO-345760	2-T1A	ET-328578	2-TR9A	SK-344589C	6-9
EC-314990	2-C69A	EO-347162	2-L2	ET-328578	2-TR2A	SK-344590B	6-10P
EC-314992	2-C61A	EO-669273	2-L1	ET-328578	2-TR7A	SK-344590C	6-10
EC-314993	2-C64	EP-337067	2-RL1A	ET-328578	2-TR8A	SP-344057	1-72
EC-320548	4-C1C	ER-318248	2-FR3A	ET-328868	2-TR6A	SP-344577B	6-3P
EC-321482	2-C79A	ER-326616	2-R4A	ET-330607	2-TR27A	SP-344591A	6-17
EC-337777	2-C57A	ER-333654	4-R10	ET-337258	2-TR26A	SP-344591B	6-17P
EC-338396	4-C1U	ER-337695	2-FL1A	ET-344102	1-111	SP-344592A	5-11U
EC-338396	4-C1J	ER-337696	2-FL2A	ET-344102	1-112	SP-344592B	5-11J
EC-338411	4-C1E	ER-344278	3-CR2A	ET-346298	3-TR4A	SP-344592C	5-11C
EC-345808	3-CR1A	ER-345757	3-CR3A	EV-338467	2-VR7A	SP-344592D	5-11E
ED-301911	2-D5A	ES-305733	5-7	EV-342940	2-VR3A	SP-344592E	5-11V
ED-301911	2-D7A	ES-336780	3-SW3B	EV-342940	2-VR1A	SP-344592F	5-11B
ED-301911	2-D6A	ES-336780	3-SW7B	EV-342942	2-VR6A	TC-344062	1-97
ED-301911	2-D9A	ES-336780	3-SW9B	EV-342942	2-VR5A	TC-344097	1-50
ED-301911	2-D8A	ES-336780	3-SW15B	EV-345612	2-VR2A	ZG-312923	1-36
ED-301911	2-D13A	ES-336780	3-SW14B	EV-522652	3-VR1A	ZG-312925	1-40
ED-301911	2-D12A	ES-336780	3-SW13B	EW-347601	5-3U	ZG-312945	1-92
ED-301911	2-D11A	ES-336780	3-SW8B	EW-347602	5-3E	ZG-336615	1-73
ED-306109	4-D6	ES-336780	3-SW6B	EW-347603	5-3S	ZG-343193	1-43
ED-310340	1-96	ES-336780	3-SW1B	EW-347679	5-3B	ZG-343195	1-33
ED-330319	4-D8	ES-336780	3-SW2B	EW-347836	5-3J	ZG-344012	1-13
ED-330319	4-D5	ES-336780	3-SW5B	EW-348215	5-3C	ZG-344013	1-19
ED-336998	4-D4	ES-336780	3-SW4B	HR-344103	1-6	ZG-344031	1-55
ED-337575	2-D4A	ES-336814	1-98	HZ-B344006	1-5	ZG-344058A	1-75
ED-337575	2-D10A	ES-337843	3-SW16B	HZ-B344009	1-4	ZG-344064	1-63
ED-337575	3-D9A	ES-337843	3-SW17B	HZ-344011	1-9	ZG-344089	1-83
ED-337575	3-D2A	ES-344101	1-90	HZ-344015	1-22	ZG-344090	1-91
ED-337575	3-D4A	ES-344104	1-20	HZ-344093	1-26	ZG-344091	1-103
ED-337575	3-D3A	ES-344253	1-100	MB-344028	1-67	ZG-344749	6-5
ED-337575	3-D1A	ES-344253	1-102	MB-344034	1-39	ZG-344939	1-74
ED-337575	3-D7A	ES-344257	1-101	MB-344041	1-68	ZG-345660	1-86
ED-337575	3-D11A	ES-344257	1-99	MB-344042	1-69	ZG-345661	1-87
ED-337575	4-D3	ES-344270	4-SW1	MB-344043	1-53	ZG-349016	1-41
ED-337575	4-D1	ES-345838	3-SW19B	MB-344088	1-107	ZS-245147	1-8
ED-337776	2-D1A	ET-200505	2-TR29A	MB-345139	1-32	ZS-314702	5-2
ED-337868	4-D11	ET-200505	2-TR22A	MB-349019	1-88	ZS-320906	5-8
ED-337868	4-D9	ET-200505	2-TR16A	MI-344094	1-30	ZS-321194	1-78
ED-338013	4-D2	ET-200505	2-TR15A	MI-344095	1-31	ZS-331567	6-16
ED-338454	3-D10A	ET-200505	2-TR19A	ML-344032	1-37	ZS-336613	1-62
ED-345820	3-D6A	ET-200505	2-TR18A	ML-344033	1-38	ZS-337783	5-9
ED-345821	3-D8A	ET-200505	2-TR23A	ML-344053	1-77	ZS-343113	1-71
ED-345822	4-D10	ET-200505	2-TR32A	ML-344096	1-49	ZS-343125	1-21
ED-345822	4-D7	ET-200505	3-TR10A	ML-344286	1-76	ZS-343136	1-45
ED-560913	3-D5A	ET-200505	3-TR1A	MP-336153	1-82	ZS-344001	1-10
EF-305703	5-4C	ET-200505	3-TR9A	MR-B344076	1-94	ZS-345314	1-54
EF-305703	5-5C	ET-200505	3-TR13A	MR-344037	1-52	ZS-345773	1-23
EF-306124	5-4U	ET-200505	3-TR12A	MR-344080	1-104	ZS-346048	5-12
EF-306124	5-5U	ET-200505	3-TR8A	MV-666887	1-42	ZS-432843	1-17
EF-308848	5-6C	ET-200505	4-TR2	MZ-B344008	1-3	ZS-455207	6-18
EF-309389	5-6U	ET-200505	4-TR5	MZ-B344018	1-29	ZS-477876	1-106
EF-601942	5-5E	ET-200505	4-TR7	MZ-344002	1-16	ZS-524812	1-24
EF-601942	5-4E	ET-200558	2-TR31A	MZ-344004	1-12	ZS-592378	1-110
EF-668474	5-6E	ET-200558	2-TR30A	MZ-344007	1-18	ZS-608095	1-25
EI-330352	3-IC5A	ET-200558	3-TR11A	MZ-344019	1-60	ZW-268222	1-34
EI-336761	2-IC5A	ET-200558	3-TR14A	MZ-344020	1-61	ZW-270088	1-46

# INDEX

## 1. HX-R5

PARTS NO.	REF. NO.	PARTS NO.	REF. NO.	PARTS NO.	REF. NO.	PARTS NO.	REF. NO.
ZW-270088	1-89						
ZW-273734	1-11						
ZW-305013	5-14x						
ZW-305546	1-93						
ZW-305546	1-51						
ZW-329422	1-35						
ZW-343120	1-58						
ZW-343120	1-48						
ZW-343120	1-95						
ZW-344047	1-65						
ZW-344639A	1-27						
ZW-344639B	1-27						
ZW-344639C	1-27						
ZW-344639D	1-27						
ZW-344639E	1-27						
ZW-344639F	1-27						
ZW-344639G	1-27						
ZW-344639H	1-27						
ZW-344639J	1-27						
ZW-349046	1-59						
ZW-349047	1-66						
ZW-381644	1-56						
ZW-391397	1-15						
ZW-618884	1-14						
ZW-698308	5-10						

# INDEX

## 2. GX-R6

PARTS NO.	REF. NO.	PARTS NO.	REF. NO.	PARTS NO.	REF. NO.	PARTS NO.	REF. NO.
BA-T2046A020A	2-1	EI-336761	2-1C5A	ET-200505	4-TR5	MZ-B344018	1-29
BA-T2046A030A	3-1	EI-337008	3-1C2A	ET-200505	4-TR7	MZ-344002	1-16
BD-B343023C	6-21	EI-337008	3-1C3A	ET-200558	3-TR2A	MZ-344004	1-12
BD-B343023D	6-21P	EI-337009	3-1C7A	ET-200558	3-TR3A	MZ-344007	1-18
BD-B344049A1	1-79	EI-337009	3-1C8A	ET-200558	3-TR5A	MZ-344019	1-60
BD-T2046A050A	6-1	EI-337009	3-1C9A	ET-200558	3-TR6A	MZ-344020	1-61
BD-T2046A050B	6-1P	EI-337013	3-1C6A	ET-200558	3-TR7A	MZ-344036	1-47
BD-344577A	6-3	EI-337013	3-1C2B	ET-200558	3-TR11A	MZ-344039	1-44
BF-344029	1-64	EI-337013	3-1C3B	ET-200558	3-TR14A	MZ-344083	1-108
BH-T2045A030B	1-2	EI-337013	3-1C4B	ET-200558	3-TR1	MZ-344099	1-70
BL-T2045A050A	1-80	EI-337017	3-X1A	ET-200558	4-TR3	SA-343007	5-13
BL-T2045A060A	1-81	EI-337228	2-1C6A	ET-307349	2-TR5A	SK-343009	6-17
BM-B604490	1-105	EI-337228	2-1C1A	ET-309353	2-TR14A	SK-343009B	6-17P
BM-B604491	1-109	EI-337835	2-1C3A	ET-309353	2-TR20A	SK-343014B	6-11
BR-344098	1-57	EI-337845	3-1C1B	ET-309353	2-TR21A	SK-343014D	6-12
BT-347803	5-1U	EI-344291	2-1C2A	ET-310148	4-TR4	SK-343017A	6-2
BT-347804	5-1E	EI-345759	3-1C4A	ET-310148	4-TR6	SK-343017B	6-2P
BT-347805	5-1B	EI-348465	3-1C1A	ET-310341	1-85	SK-344578A	6-4
BT-348945	5-1J	EJ-344640	2-J2B	ET-311977	1-84	SK-344578B	6-4P
BT-348946	5-1C	EJ-345812	2-J1B	ET-328578	2-TR1A	SK-344581A	6-6
BZ-T2045A020B	1-1	EJ-346076	2-J2A	ET-328578	2-TR2A	SK-344581B	6-6P
BZ-T2045A040A	1-28	EJ-347664	2-J1A	ET-328578	2-TR3A	SK-344583A	6-7
EA-343944	1-7	EL-348214	1-113	ET-328578	2-TR4A	SK-344583B	6-7P
EC-201761	4-C5	EM-345810	3-IN1B	ET-328578	2-TR8A	SK-344584A	6-13
EC-201761	4-C6	EO-315758	2-FL4A	ET-328578	2-TR10A	SK-344584B	6-13P
EC-310440	2-C69A	EO-337044	2-FL3A	ET-328578	2-TR11A	SK-344584C	6-14
EC-314992	2-C61A	EO-337055	2-VL1A	ET-328578	2-TR12A	SK-344584D	6-14P
EC-314992	2-C85A	EO-345836	2-T1A	ET-328578	2-TR13A	SK-344584E	6-15
EC-320548	4-C1C	EO-669273	2-L1A	ET-328578	2-TR9A	SK-344584F	6-15P
EC-321482	2-C79A	EP-337067	2-RL1A	ET-328578	2-TR24A	SK-344585A	6-16
EC-335306	2-C57A	ER-318248	2-FR3A	ET-328578	2-TR25A	SK-344585B	6-16P
EC-338396	4-C1U	ER-326616	2-R4A	ET-328578	2-TR28A	SK-344587B	6-8P
EC-338396	4-C1J	ER-333654	4-R10	ET-328868	2-TR6A	SK-344587C	6-8
EC-338411	4-C1E	ER-337695	2-FL1A	ET-330607	2-TR27A	SK-344589B	6-9P
EC-345808	3-CR1A	ER-337696	2-FL2A	ET-337258	2-TR26A	SK-344589C	6-9
ED-301911	2-D5A	ER-344278	3-CR2A	ET-344102	1-111	SK-344590B	6-10P
ED-301911	2-D6A	ER-345757	3-CR3A	ET-344102	1-112	SK-344590C	6-10
ED-301911	2-D7A	ES-305733	5-7	ET-346298	3-TR4A	SP-344057	1-72
ED-301911	2-D8A	ES-336780	3-SW1B	EV-337841	2-VR1C	SP-344577B	6-3P
ED-301911	2-D9A	ES-336780	3-SW2B	EV-338467	2-VR7A	SP-344591A	6-19
ED-301911	2-D11A	ES-336780	3-SW3B	EV-342939	2-VR4A	SP-344591B	6-19P
ED-301911	2-D12A	ES-336780	3-SW4B	EV-342940	2-VR1A	SP-344592A	5-11U
ED-301911	2-D13A	ES-336780	3-SW5B	EV-342942	2-VR6A	SP-344592B	5-11J
ED-305704	2-D1A	ES-336780	3-SW6B	EV-342942	2-VR5A	SP-344592C	5-11C
ED-306109	4-D6	ES-336780	3-SW7B	EV-345610	2-VR2A	SP-344592D	5-11E
ED-310340	1-96	ES-336780	3-SW8B	EV-345611	2-VR3A	SP-344592E	5-11V
ED-330319	4-D5	ES-336780	3-SW9B	EV-522652	3-VR1A	SP-344592F	5-11B
ED-330319	4-D8	ES-336780	3-SW10B	EW-347601	5-3U	TC-344062	1-97
ED-336998	4-D4	ES-336780	3-SW11B	EW-347602	5-3E	TC-344097	1-50
ED-337575	2-D4A	ES-336780	3-SW12B	EW-347603	5-3S	ZG-312923	1-36
ED-337575	2-D10A	ES-336780	3-SW13B	EW-347679	5-3B	ZG-312925	1-40
ED-337575	3-D1A	ES-336780	3-SW14B	EW-347836	5-3J	ZG-312945	1-92
ED-337575	3-D2A	ES-336780	3-SW15B	EW-348215	5-3C	ZG-336615	1-73
ED-337575	3-D3A	ES-336814	1-98	HR-H2501A010A	1-6	ZG-343193	1-43
ED-337575	3-D4A	ES-337843	3-SW18B	HZ-B344006	1-5	ZG-343195	1-33
ED-337575	3-D9A	ES-337843	3-SW16B	HZ-B344009	1-4	ZG-344012	1-13
ED-337575	3-D7A	ES-337843	3-SW17B	HZ-344011	1-9	ZG-344013	1-19
ED-337575	3-D11A	ES-344101	1-90	HZ-344015	1-22	ZG-344031	1-55
ED-337575	4-D1	ES-344104	1-20	HZ-344093	1-26	ZG-344058A	1-75
ED-337575	4-D3	ES-344253	1-100	MB-344028	1-67	ZG-344064	1-63
ED-337868	4-D9	ES-344253	1-102	MB-344034	1-39	ZG-344089	1-83
ED-337868	4-D11	ES-344257	1-99	MB-344041	1-68	ZG-344090	1-91
ED-338013	4-D2	ES-344257	1-101	MB-344042	1-69	ZG-344091	1-103
ED-338454	3-D10A	ES-344270	4-SW1	MB-344043	1-53	ZG-344749	6-5
ED-345820	3-D6A	ES-345838	3-SW19B	MB-344088	1-107	ZG-344939	1-74
ED-345821	3-D8A	ET-200505	2-TR15A	MB-345139	1-32	ZG-345660	1-86
ED-345822	4-D7	ET-200505	2-TR16A	MB-349019	1-88	ZG-345661	1-87
ED-345822	4-D10	ET-200505	2-TR18A	MI-344094	1-30	ZG-349016	1-41
ED-560913	3-D5A	ET-200505	2-TR19A	MI-344095	1-31	ZS-245147	1-8
EF-305703	5-4C	ET-200505	2-TR23A	ML-344032	1-37	ZS-314702	5-2
EF-305703	5-5C	ET-200505	2-TR22A	ML-344033	1-38	ZS-320906	5-8
EF-306124	5-4U	ET-200505	2-TR32A	ML-344053	1-77	ZS-321194	1-78
EF-306124	5-5U	ET-200505	2-TR29A	ML-344096	1-49	ZS-331567	6-16
EF-308848	5-6C	ET-200505	3-TR1A	ML-344286	1-76	ZS-336613	1-62
EF-309389	5-6U	ET-200505	3-TR8A	MP-336153	1-82	ZS-337783	5-9
EF-601942	5-4E	ET-200505	3-TR9A	MR-B344076	1-94	ZS-343113	1-71
EF-601942	5-5E	ET-200505	3-TR10A	MR-344037	1-52	ZS-343125	1-21
EF-668474	5-6E	ET-200505	3-TR12A	MR-344080	1-104	ZS-343136	1-45
EI-330352	3-1C5A	ET-200505	3-TR13A	MV-666887	1-42	ZS-344001	1-10
EI-336761	2-1C4A	ET-200505	4-TR2	MZ-B344008	1-3	ZS-345314	1-54

# INDEX

## 2. GX-R6

PARTS NO.	REF. NO.	PARTS NO.	REF. NO.	PARTS NO.	REF. NO.	PARTS NO.	REF. NO.
ZS-345773	1-23						
ZS-346048	5-12						
ZS-432843	1-17						
ZS-455207	6-18						
ZS-477876	1-106						
ZS-524812	1-24						
ZS-592378	1-110						
ZS-608095	1-25						
ZW-268222	1-34						
ZW-270088	1-46						
ZW-270088	1-89						
ZW-273734	1-11						
ZW-305013	5-14x						
ZW-305546	1-93						
ZW-305546	1-51						
ZW-329422	1-35						
ZW-343120	1-58						
ZW-343120	1-48						
ZW-343120	1-95						
ZW-344047	1-65						
ZW-344639A	1-27						
ZW-344639B	1-27						
ZW-344639C	1-27						
ZW-344639D	1-27						
ZW-344639E	1-27						
ZW-344639F	1-27						
ZW-344639G	1-27						
ZW-344639H	1-27						
ZW-344639J	1-27						
ZW-349046	1-59						
ZW-349047	1-66						
ZW-381644	1-56						
ZW-391397	1-15						
ZW-618884	1-14						
ZW-698308	5-10						

SECTION 3

# SCHEMATIC DIAGRAM

## TABLE OF CONTENTS

1. SCHEMATIC DIAGRAM OF ICs.....	53
2. HX-R5 POWER SYSCON No. 2-1 830410A SCHEMATIC DIAGRAM .....	61
3. HX-R5 AMP No. 2-2 830411A SCHEMATIC DIAGRAM .....	62
4. GX-R6 POWER SYSCON NO. 2-1 830412A SCHEMATIC DIAGRAM .....	63
5. GX-R6 AMP No. 2-2 830413A SCHEMATIC DIAGRAM .....	64

BA6109

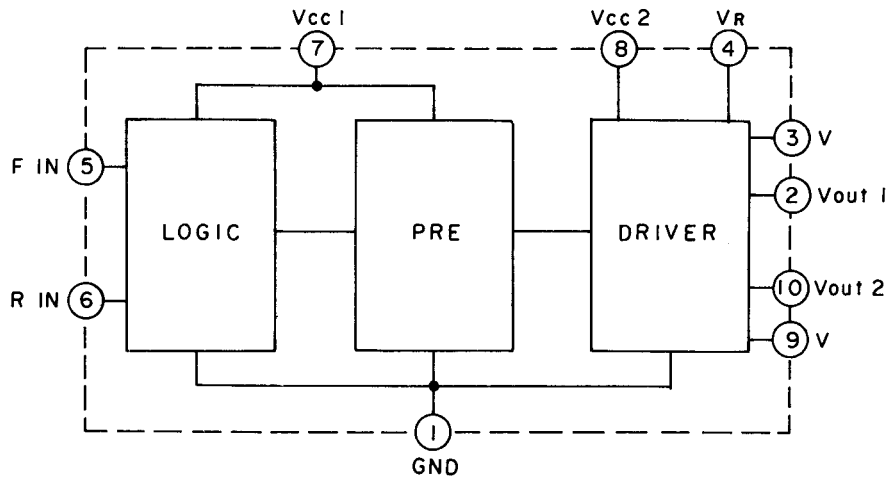

BA6146

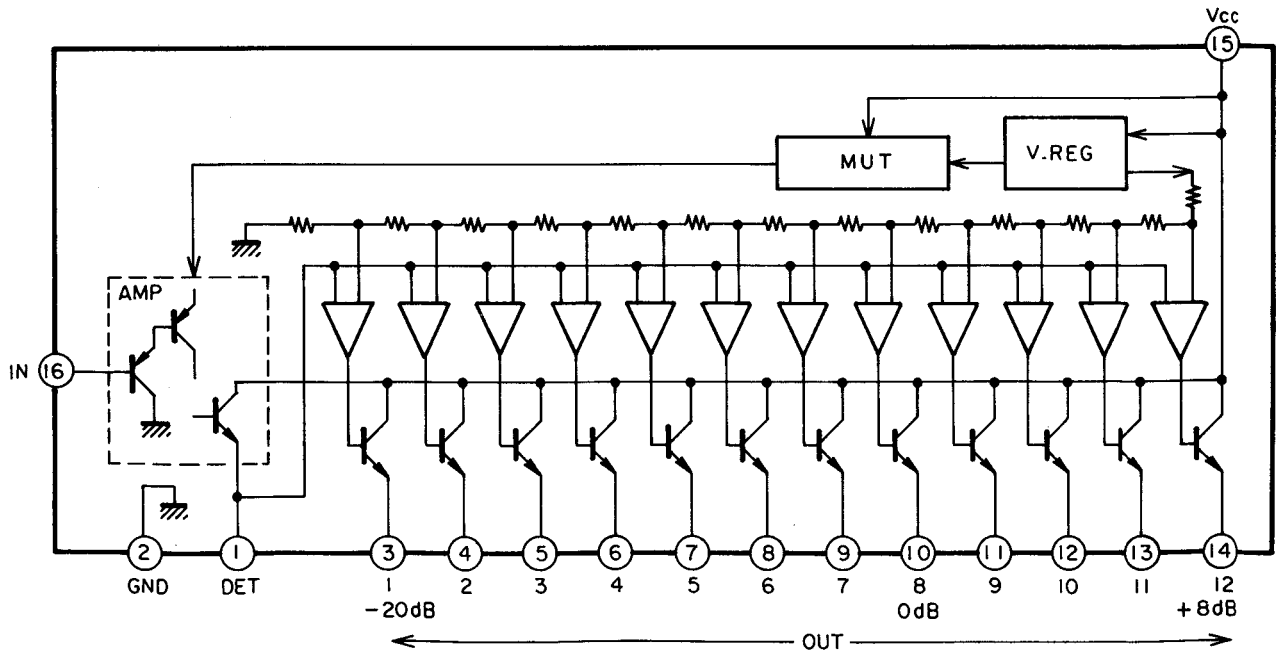

LA6458S

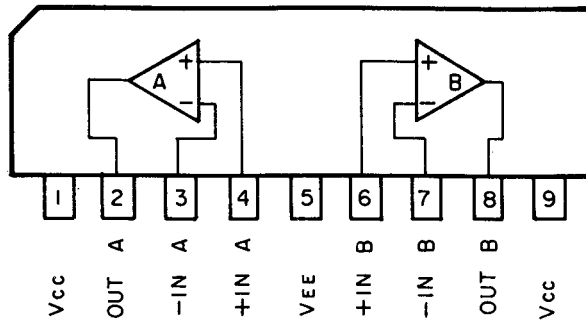

LB1290

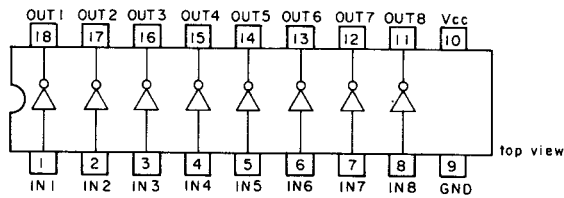
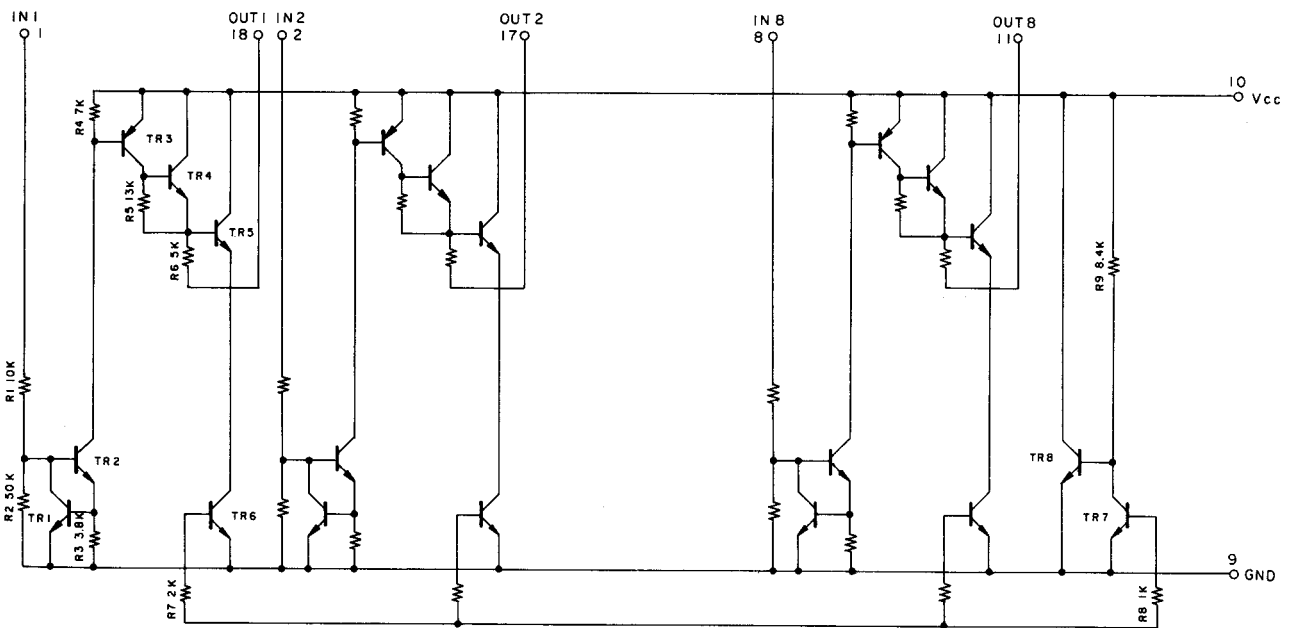



LC4049B

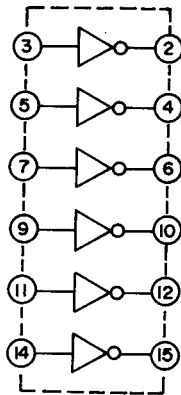

NC= Pin 13,16  
 VSS= Pin 8  
 VCC= Pin 1

LC7530

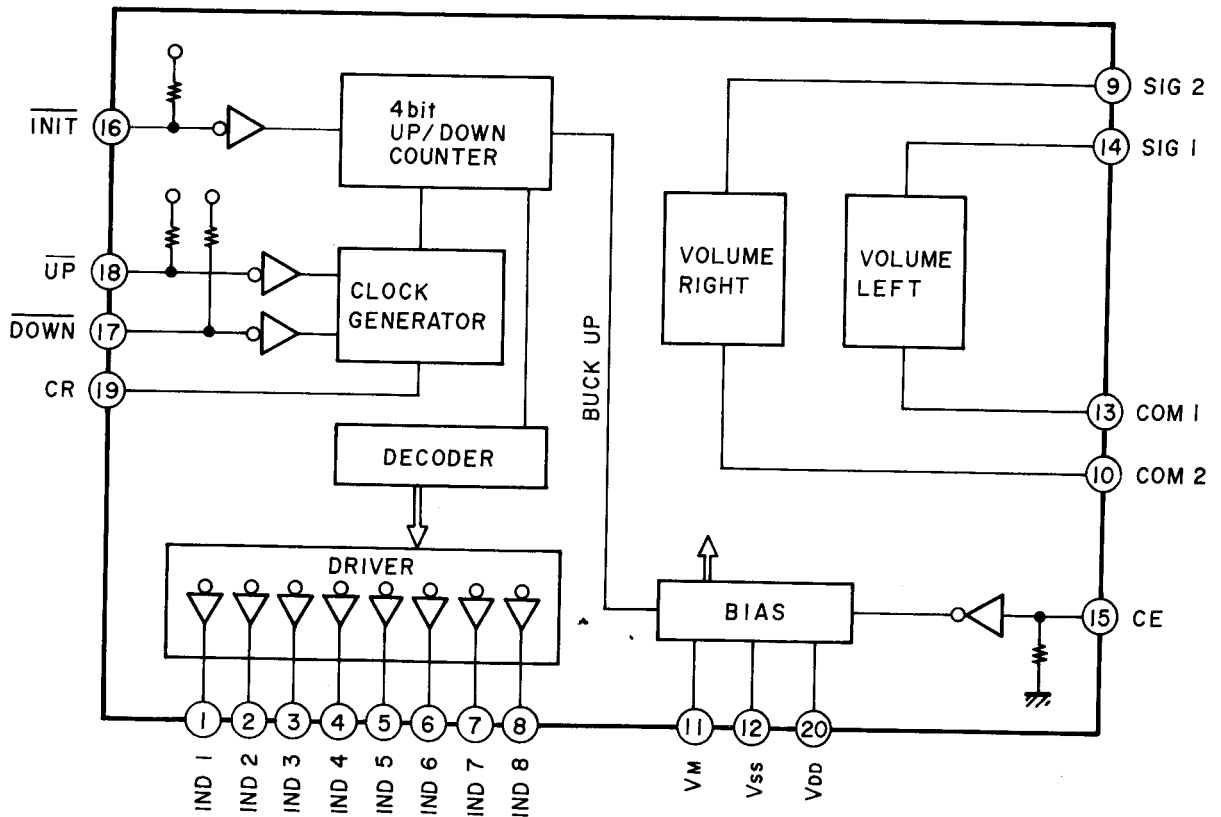

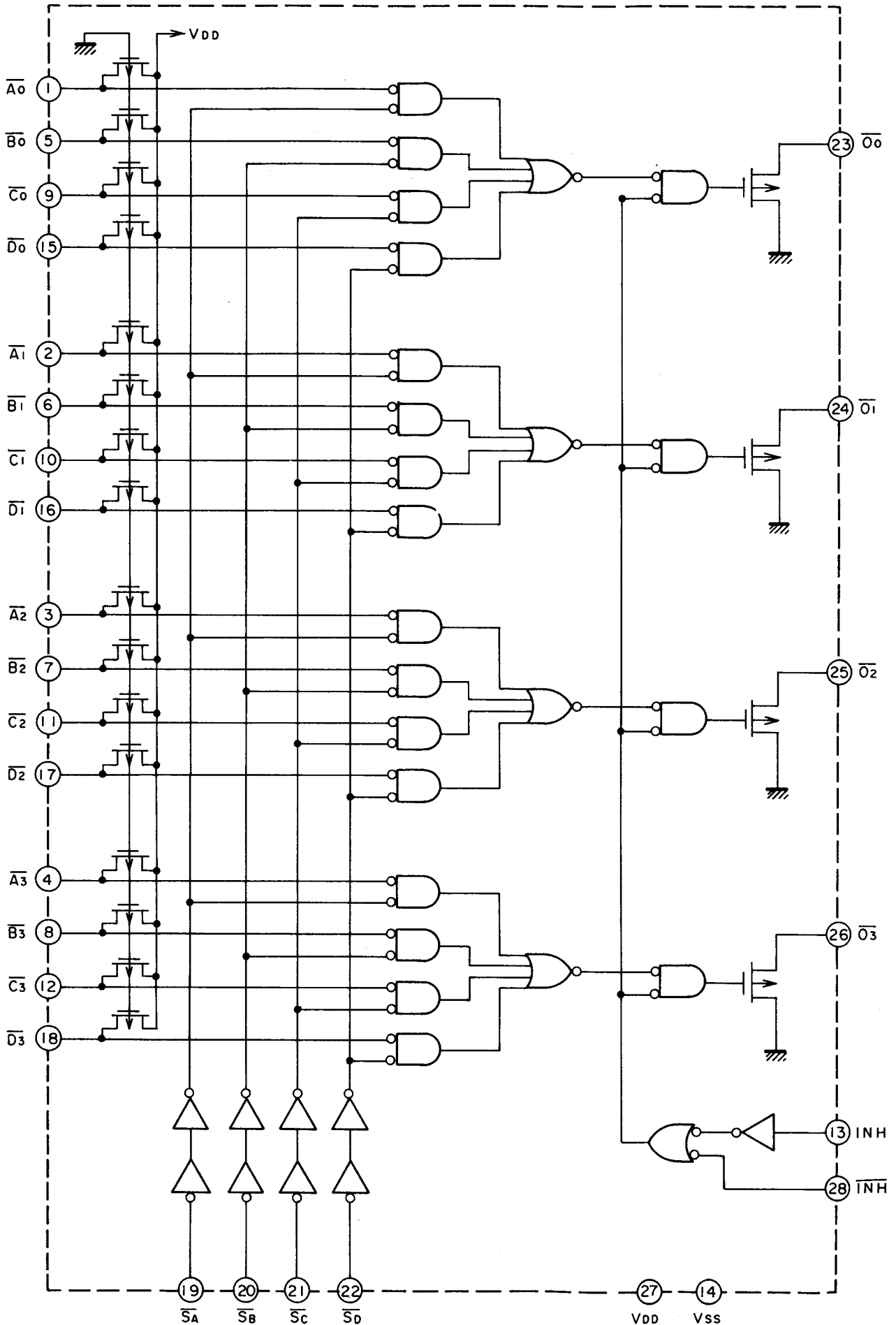

Connection of each terminal of IC (LC7800) for expanding IC1 (LM6402H-190) Input Port.

Pin No.	Symbol	Items connected to IC2	Items connected to IC3
1	A0	Stop SW	Cam rotation direction SW
2	A1	FWD SW	FWD/REV SW
3	A2	REV SW	Anti REC FWD SW
4	A3	REC SW	Anti REC REV SW
5	B0	FF SW	CrO <sub>2</sub> SW
6	B1	REW SW	Metal SW
7	B2	Auto Mute SW	Timer SW (REC)
8	B3	REC Cancel SW	Timer SW (PLAY)
9	C0	Intro Scan SW	+5V
10	C1	BSS SW	+5V
11	C2	Reverse Selector SW	+5V
12	C3	IPLS SW	+5V
13	INH	GND	IC1 Pin 19 (F3)
14	VSS	GND	GND
15	D0	Counter Reset SW	Music Interval Detector (IPLS)
16	D1	+5V	Quick Reverse Detector
17	D2	+5V	GND
18	D3	+5V	+5V
19	SA	IC1 Pin 11 (D3)	IC1 Pin 11 (D3)
20	SB	IC1 Pin 10 (D2)	IC1 Pin 10 (D2)
21	SC	IC1 Pin 9 (D1)	IC1 Pin 9 (D1)
22	SD	IC1 Pin 8 (D0)	IC1 Pin 8 (D0)
23	00	IC1 Pin 5 (C3)	IC1 Pin 5 (C3)
24	01	IC1 Pin 4 (C2)	IC1 Pin 4 (C2)
25	02	IC1 Pin 3 (C1)	IC1 Pin 3 (C1)
26	03	IC1 Pin 2 (C0)	IC1 Pin 2 (C0)
27	VDD	+5V	+5V
28	INH	IC1 Pin 19 (F3)	+5V

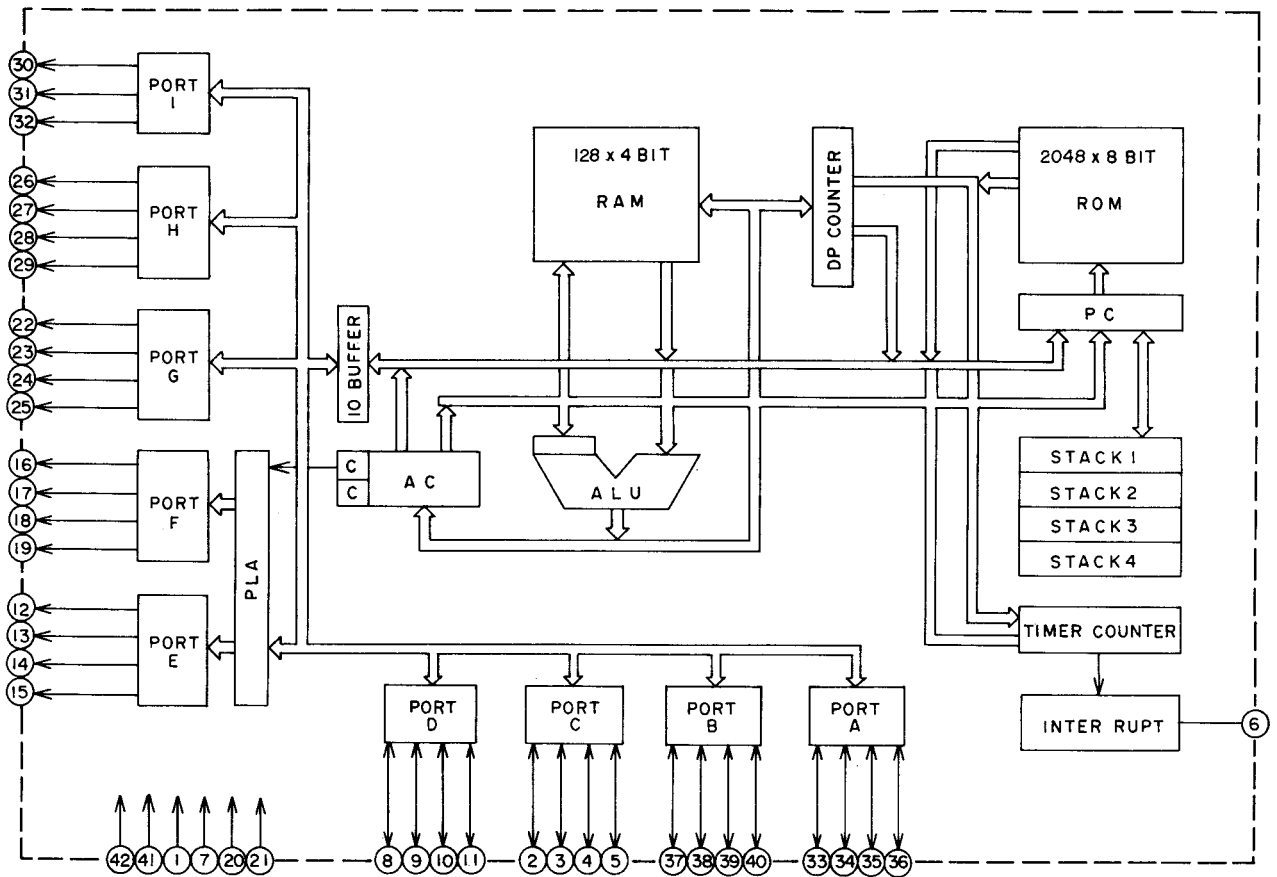

Pin No.	Symbol	Description
1	XTAL	Xin
2	C0	Data Input 1
3	C1	Data Input 2
4	C2	Data Input 3
5	C3	Data Input 4
6	INT	Cam Motor Pulse Input
7	RES	Reset
8	D0	Electronic Counter 1 Digit
9	D1	Electronic Counter 2 Digit
10	D2	Electronic Counter 3 Digit
11	D3	Electronic Counter 4 Digit
12	E0	7 Segment Drive Output a
13	E1	7 Segment Drive Output b
14	E2	7 Segment Drive Output c
15	E3	7 Segment Drive Output d
16	F0	7 Segment Drive Output e
17	F1	7 Segment Drive Output f
18	F2	7 Segment Drive Output g
19	F3	Strobe for Input Port Select
20	TEST	GND
21	VSS	GND
22	G0	Reverse
23	G1	Forward

Output, Light ON at "L"

Cam Motor Control Output

Pin No.	Symbol	Description
24	G2	CONTI. REV
25	G3	ONCE REV
26	H0	IPLS
27	H1	REC
28	H2	REV
29	H3	FWD
30	I0	Metal
31	I1	CrO <sub>2</sub>
32	I2	Normal
33	A0	External Control output. No connect
34	A1	Reel Rotation Pulse Input.
35	A2	Cam Direction Detector Input.
36	A3	Cam Mode Stop Detector Input.
38	B1	REC MUTE
38	B1	PB MUTE
39	B2	O.S.C. Control output, activates at "L".
40	B3	REC/PB Control, "H" → PB, "L" → REC.
41	VDD	+5V
42	EXTAL	EXin

FLD Drive Output, Lights ON at "L".

Output, activates at "H".

M5218LO

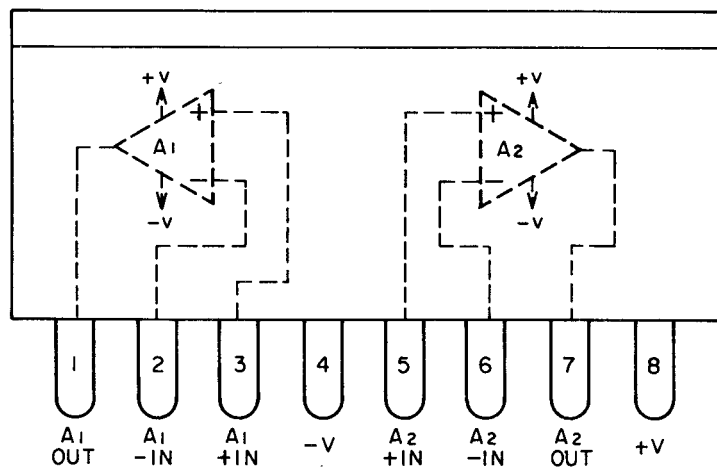

NE652

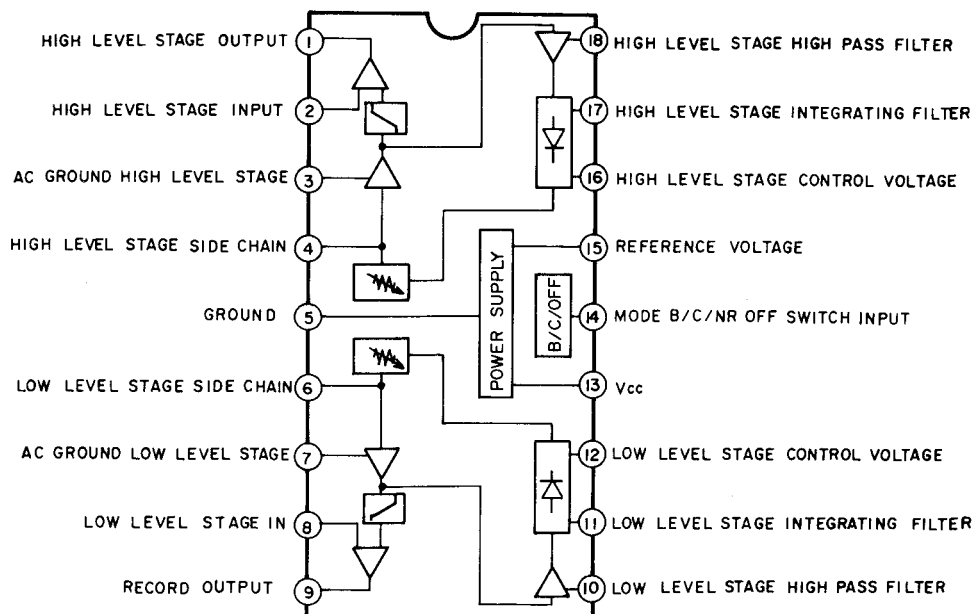

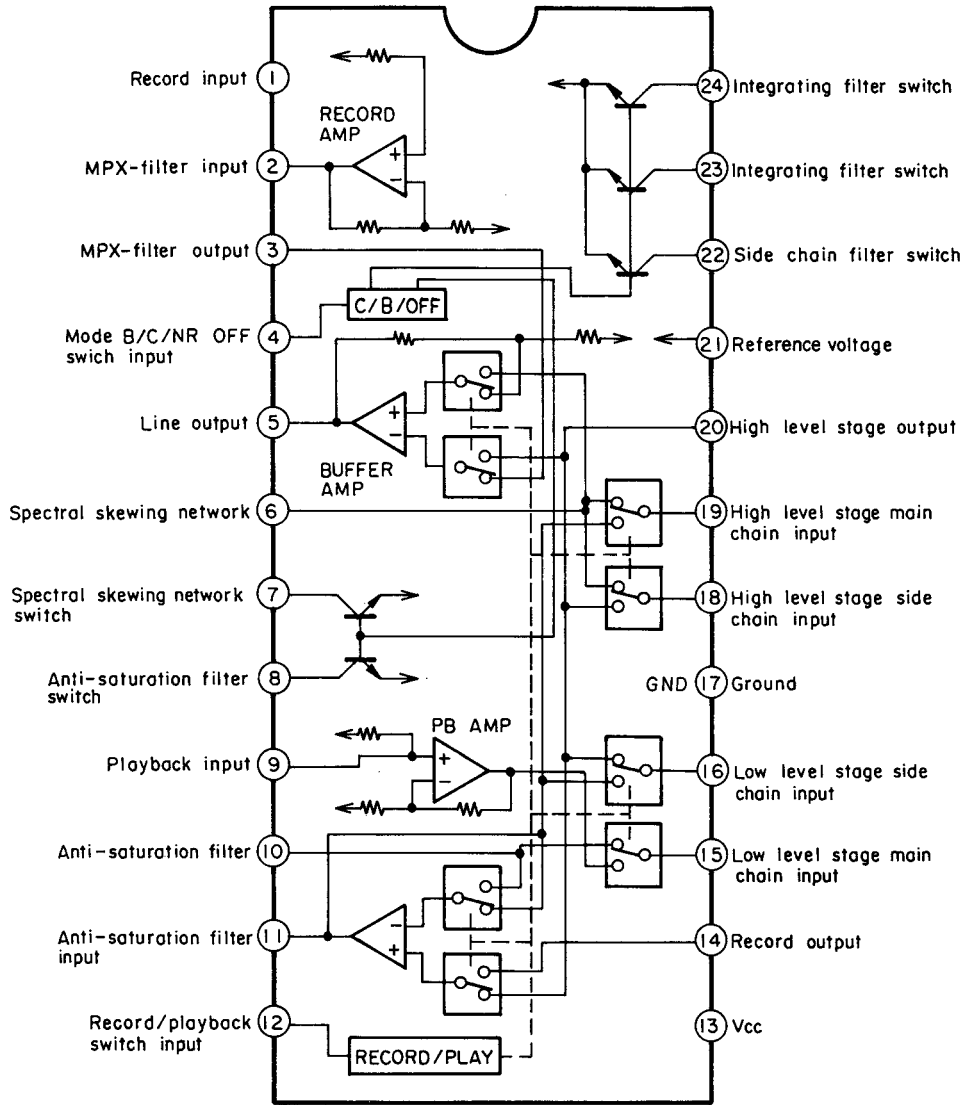

TA78L005AP

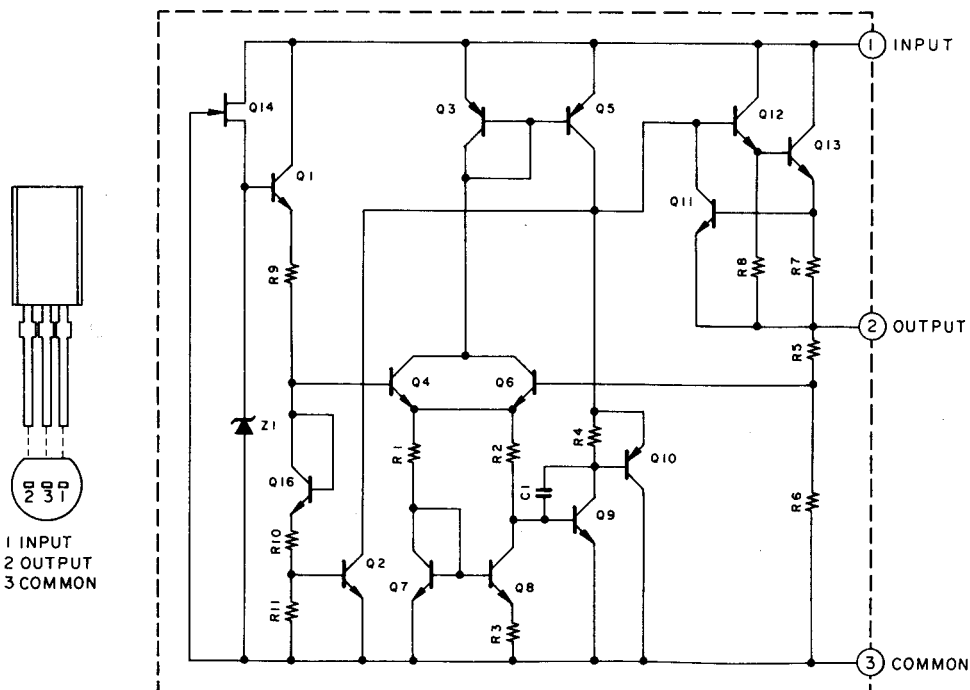

HX-R5

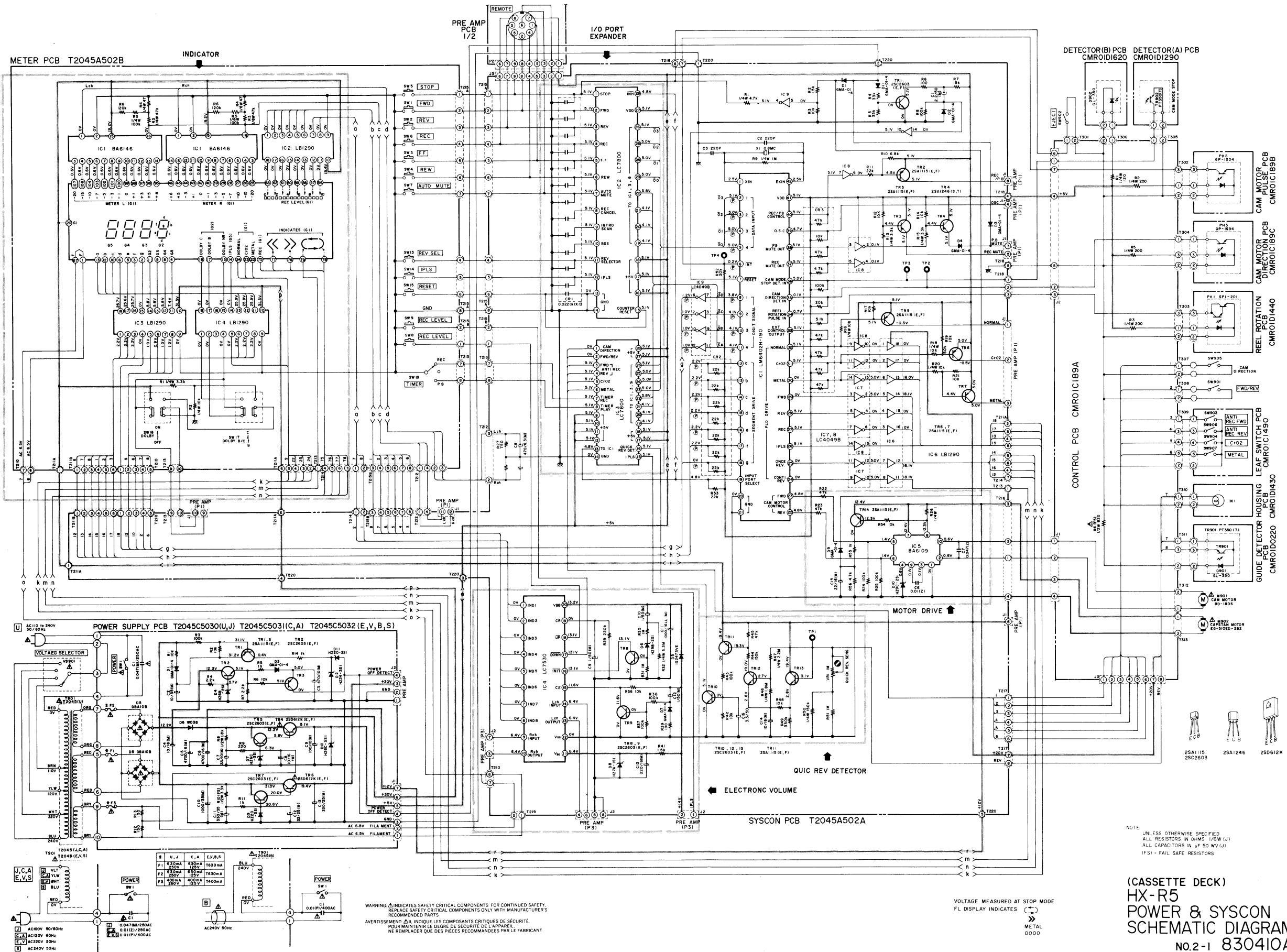

POWER SUPPLY PCB T2045C503(U,J) T2045C503(C,A) T2045C503(E,V,B,S)

VOLTAGE SELECTOR

WARNING: INDICATES SAFETY CRITICAL COMPONENTS. FOR CONTINUED SAFETY, REPLACE SAFETY CRITICAL COMPONENTS ONLY WITH MANUFACTURER'S RECOMMENDED PARTS.  
 AVERTISSEMENT: ΔIL INDIQUE LES COMPOSANTS CRITIQUES DE SÉCURITÉ. POUR MAINTENIR LE DEGRÉ DE SÉCURITÉ DE L'APPAREIL, NE REMPLACER QUE DES PIÈCES RECOMMANDÉES PAR LE FABRICANT.

VOLTAGE MEASURED AT STOP MODE  
 FL DISPLAY INDICATES

(CASSETTE DECK)  
 HX-R5  
 POWER & SYSCON  
 SCHEMATIC DIAGRAM  
 NO.2-1 830410A

NOTE  
 UNLESS OTHERWISE SPECIFIED:  
 ALL RESISTORS IN OHMS (1/8W 1/4W 1/2W)  
 ALL CAPACITORS IN μF (50 WV 100 WV)  
 (FS) = FAIL SAFE RESISTORS

25A1105 25C2603 25A246 25D612K

001842

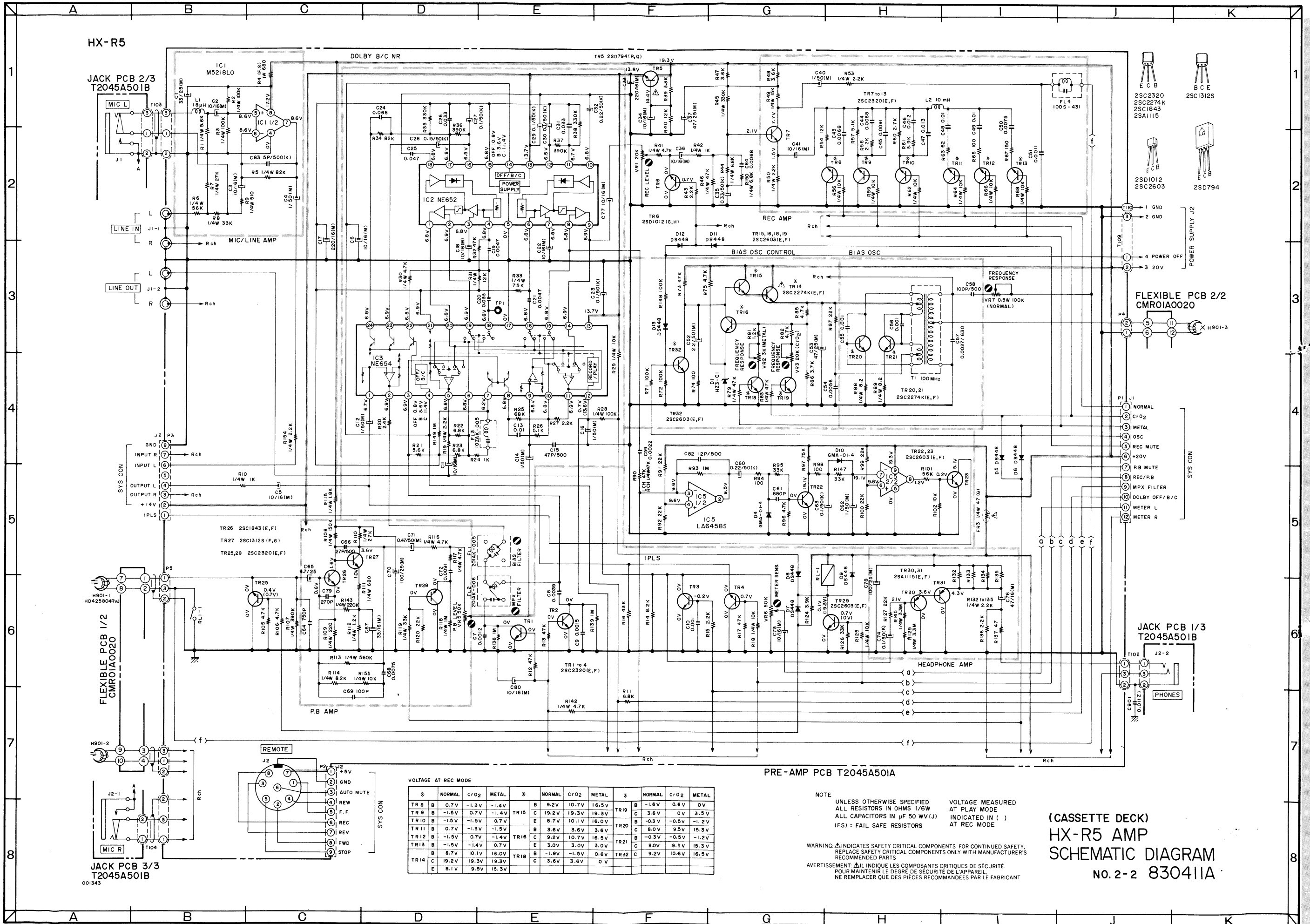

VOLTAGE AT REC MODE

* TR	NORMAL	CrO2	METAL	* TR	NORMAL	CrO2	METAL	* TR	NORMAL	CrO2	METAL
TR 8	0.7V	-1.3V	-1.4V	TR 15	9.2V	10.7V	16.5V	TR 19	-1.6V	0.6V	0V
TR 9	-1.5V	0.7V	-1.4V	TR 16	19.2V	19.3V	19.3V	TR 20	0V	0V	3.5V
TR 10	-1.5V	-1.5V	0.7V	TR 17	8.7V	10.1V	16.0V	TR 21	-0.3V	-0.5V	-1.2V
TR 11	0.7V	-1.3V	-1.5V	TR 18	3.6V	3.6V	3.6V	TR 22	8.0V	9.5V	15.3V
TR 12	-1.5V	0.7V	-1.4V	TR 19	9.2V	10.7V	16.5V	TR 23	-0.3V	-0.5V	-1.2V
TR 13	-1.5V	-1.4V	0.7V	TR 20	3.0V	3.0V	3.0V	TR 24	8.0V	9.5V	15.3V
TR 14	8.7V	10.1V	16.0V	TR 21	-1.9V	-1.5V	0.6V	TR 25	9.2V	10.6V	16.5V
TR 15	8.1V	9.5V	15.3V	TR 22	3.6V	3.6V	0V				

NOTE  
 UNLESS OTHERWISE SPECIFIED  
 ALL RESISTORS IN OHMS 1/4W  
 ALL CAPACITORS IN µF 50 WV(J)  
 (FS) = FAIL SAFE RESISTORS

VOLTAGE MEASURED  
 AT PLAY MODE  
 INDICATED IN ( )  
 AT REC MODE

WARNING: ⚠ INDICATES SAFETY CRITICAL COMPONENTS FOR CONTINUED SAFETY.  
 REPLACE SAFETY CRITICAL COMPONENTS ONLY WITH MANUFACTURER'S  
 RECOMMENDED PARTS

AVERTISSEMENT: ⚠ IL INDIQUE LES COMPOSANTS CRITIQUES DE SÉCURITÉ.  
 POUR MAINTENIR LE DEGRÉ DE SÉCURITÉ DE L'APPAREIL,  
 NE REMPLACER QUE DES PIÈCES RECOMMANDÉES PAR LE FABRICANT

(CASSETTE DECK)  
**HX-R5 AMP**  
**SCHEMATIC DIAGRAM**  
 No. 2-2 830411A



GX-R6

METER PCB T2045A502B

INDICATOR

PRE AMP PCB 1/2

I/O PORT EXPANDER

DETECTOR(B) PCB CMROI1620

DETECTOR(A) PCB CMROI1290

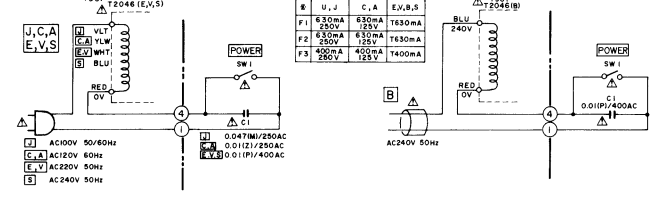
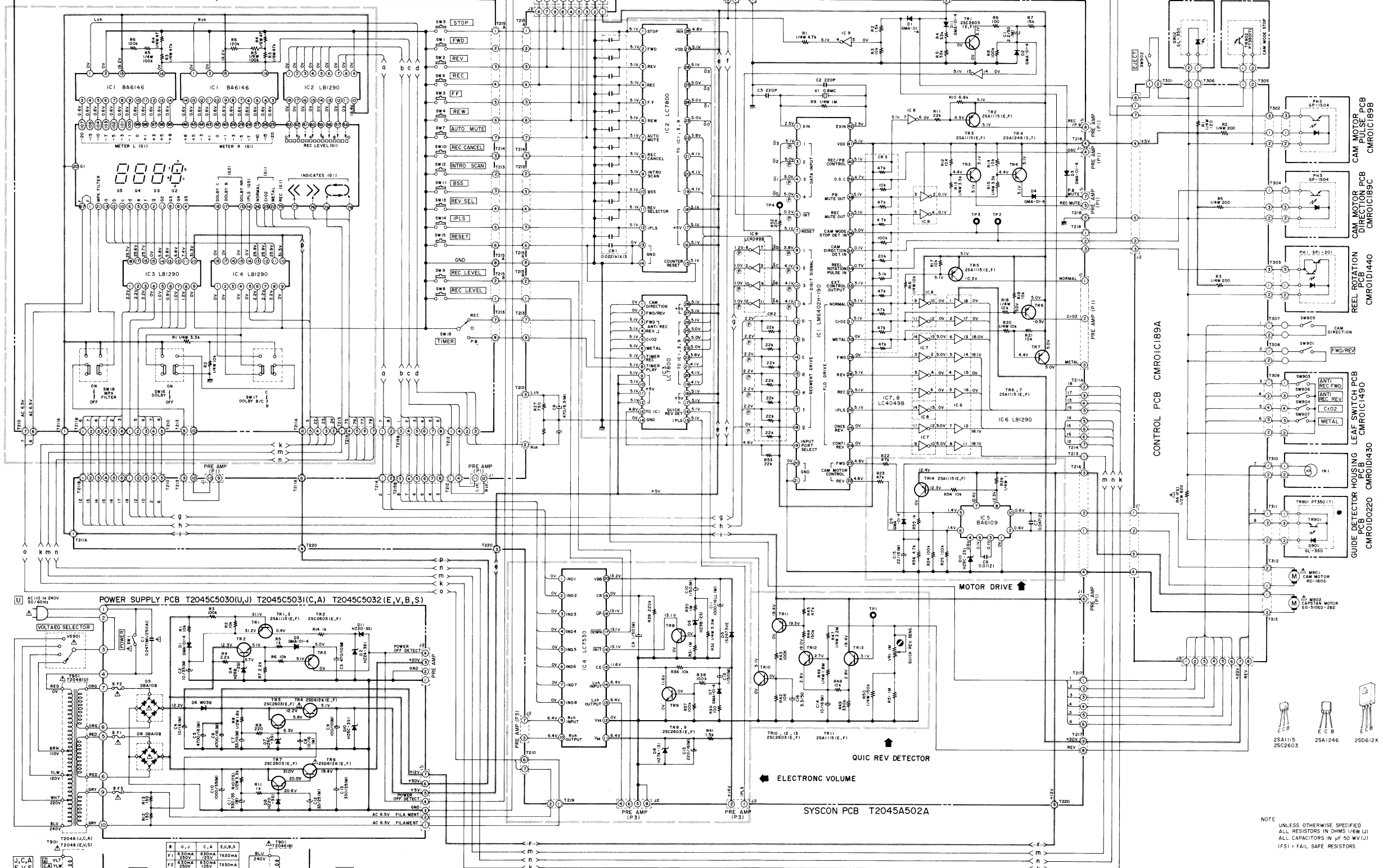

GX-R6

JACK PCB 2/3  
T2045A501B

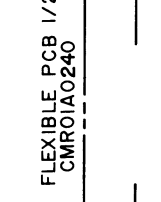
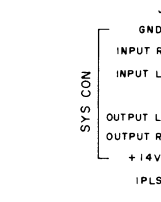
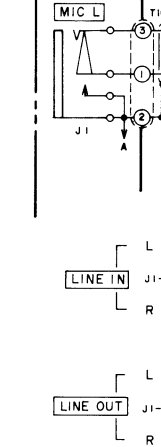

JACK PCB 3/3  
T2045A501B  
001345

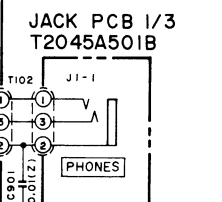
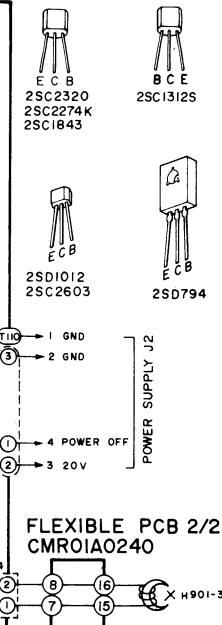
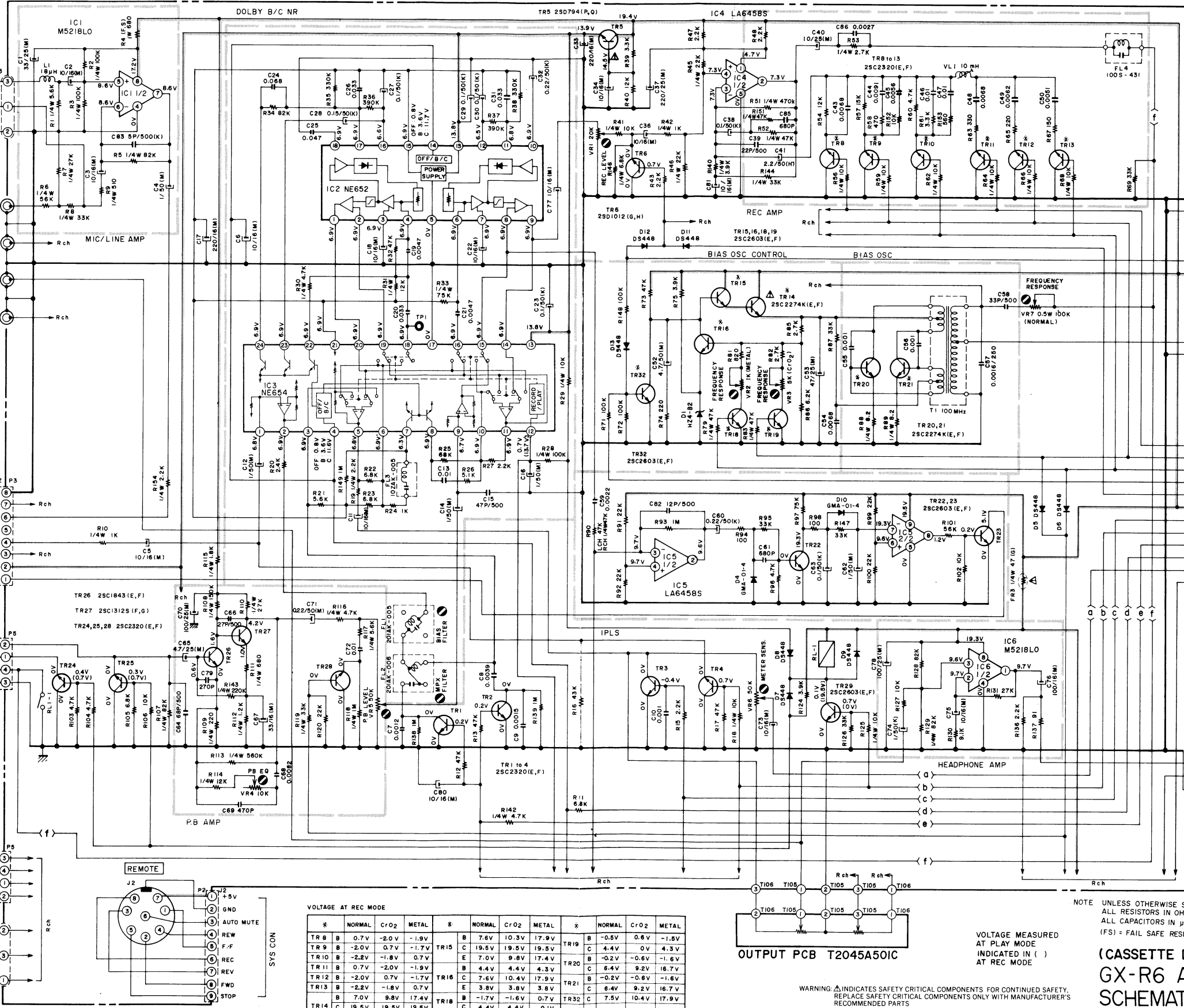

VOLTAGE AT REC MODE

X	NORMAL	CrO2	METAL	X	NORMAL	CrO2	METAL	X	NORMAL	CrO2	METAL			
TR8	B	0.7V	-2.0V	-1.9V	TR15	B	7.6V	10.3V	17.9V	TR19	B	-0.5V	0.6V	-1.5V
TR9	B	-2.0V	0.7V	-1.7V	TR16	B	19.5V	19.5V	17.4V	TR20	B	-3.2V	-0.6V	-1.6V
TR10	B	-2.2V	-1.8V	0.7V	TR17	B	7.0V	9.8V	17.4V	TR21	B	6.4V	9.2V	16.7V
TR11	B	0.7V	-2.0V	-1.9V	TR18	B	4.4V	4.4V	4.3V	TR22	B	-0.2V	-0.6V	-1.6V
TR12	B	-2.0V	0.7V	-1.7V	TR19	B	7.6V	10.4V	17.9V	TR23	B	6.4V	9.2V	16.7V
TR13	B	-2.2V	-1.8V	0.7V	TR20	B	3.8V	3.8V	3.8V	TR24	B	-1.7V	-1.6V	0.7V
TR14	B	7.0V	9.8V	17.4V	TR21	B	-1.7V	-1.6V	0.7V	TR25	B	7.5V	10.4V	17.9V
	E	19.5V	19.5V	19.5V	TR22	B	4.4V	4.4V	0.1V					

OUTPUT PCB T2045A501C

VOLTAGE MEASURED AT PLAY MODE INDICATED IN ( ) AT REC MODE

WARNING: Δ INDICATES SAFETY CRITICAL COMPONENTS. FOR CONTINUED SAFETY, REPLACE SAFETY CRITICAL COMPONENTS ONLY WITH MANUFACTURER'S RECOMMENDED PARTS.  
AVERTISSEMENT: Δ IL INDIQUE LES COMPOSANTS CRITIQUES DE SÉCURITÉ. POUR MAINTENIR LE DEGRÉ DE SÉCURITÉ DE L'APPAREIL, NE REMPLACER QUE DES PIÈCES RECOMMANDÉES PAR LE FABRICANT.

NOTE: UNLESS OTHERWISE SPECIFIED, ALL RESISTORS IN OHMS 1/6W(J), ALL CAPACITORS IN μF 50 WV(J), (FS) = FAIL SAFE RESISTORS

(CASSETTE DECK)  
GX-R6 AMP  
SCHEMATIC DIAGRAM  
NO. 2-2 830413A

# **AKAI**

## **ADDITIONAL SERVICE MANUAL**

\* This additional manual is only for the Model HX-R5/GX-R6 which used DOLBY IC HA-12038 or HA-12058 in its pre-amplifier section. Use this manual together with the HX-R5/GX-R6 Service Manual which has been published previously.

**STEREO CASSETTE DECK**

**MODEL HX-R5**

**MODEL GX-R6**

# PARTS LIST

## HX-R5

### 2. PRE AMP P.C BOARD BLOCK

REF. NO.	PARTS NO.	DESCRIPTION
2-1	BA-T2045A170A	PC PRE AMP BLK HX-R5
2-IC1A	EI-337228	IC M5218LO
2-IC11A	EI-349196	IC HA12058 (IC58)
2-IC11A	EI-336983	IC HA12038 (IC38)
2-IC12A	EI-348701	IC M51143L
2-TR1A to 3A	ET-328578	TR 2SC2320 E,F
2-TR5A	ET-307349	TR 2SD794 P,Q
2-TR6A	ET-328868	TR 2SD1012-V G,H
2-TR7A to 13A	ET-328578	TR 2SC2320 E,F
2-TR14A	ET-309353	TR 2SC2274K E,F
2-TR15A to 19A	ET-200505	TR 2SC2603 E,F
2-TR20A,21A	ET-309353	TR 2SC2274K E,F
2-TR25A	ET-328578	TR 2SC2320 E,F
2-TR26A	ET-337258	TR 2SC1843 E,F
2-TR27A	ET-330607	TR 2SC1312S F,G
2-TR28A	ET-328578	TR 2SC2320 E,F
2-TR29A	ET-200505	TR 2SC2603 E,F
2-TR30A,31A	ET-200558	TR 2SA1115 E,F
2-TR32A	ET-200505	TR 2SC2603 E,F
2-TR51A	ET-330607	TR 2SC1312S F,G
2-TR52A	ET-200505	TR 2SC2603 E,F
2-D1A	ED-337776	D ZENER H HZ3 C1
2-D5A to 9A	ED-301911	D SILICON H DS448
2-D11A to 13A	ED-301911	D SILICON H DS448
2-D21A	ED-350800	D ZENER H 05Z4.7 Y,Z
2-D22A	ED-301911	D ZENER H DS448
2-VR1A	EV-342940	R S-FIX H H0811C344A 3P 203
2-VR2A	EV-345612	R S-FIX H H0811C329A 3P 302
2-VR3A	EV-342940	R S-FIX H H0811C344A 3P 203
2-VR5A,6A	EV-342942	R S-FIX H H0811C345A 3P 503
2-VR7A	EV-338467	R S-FIX H TM8K 3P 0.30W 104
2-RL1A	EQ-337067	RELAY LEAD LAB2NS 2NO 18V
2-T1A	EO-345760	COIL OSC 1 32-5009-12 100kHz
2-L1	EO-669273	COIL FIX 2 FL5R200 180
2-L2	EO-347162	COIL FIX 1 L-8 103J
2-FL1A	EH-337695	FILTER DB 201AK-005 100kHz
2-FL2A	ER-337696	FILTER DB 201AK-006 19kHz
2-FL4A	EO-315758	COIL TUN 1 100S-431 100.00kHz
2-FL11A	EO-337044	COIL TUN 1 102AK-005
2-J1A	EJ-347664	PIN J YKC21-5053 P 4P
2-J2A	EJ-346076	DIN J TCS4690-01-1111 P 8P
2-FR3A	ER-318248	△ R FUSE ERD2FC S10 1/4W 47ROG
2-R4A	ER-326616	R OMF SNP FS 1W 681J
2-C57A	EC-337777	C PP V F10 ECQ-F 272J 630DC
2-C61A	EC-314992	C STY V F05 CQF09 681J 50DC
2-C64	EC-314993	C STY V SNP CQFS 751J 50DC
2-C69A	EC-314990	C STY V SNP CQFS 101J 50DC
2-C79A	EC-321482	C STY V F05 500 271J 50DC
2-J1B	EJ-345812	PHONE J HLJ0527-3714
2-J2B	EJ-344640	PHONE J HLJ4308-3034

## GX-R6

### 2. PRE AMP P.C BOARD BLOCK

REF. NO.	PARTS NO.	DESCRIPTION
2-1	BA-T2046A020A	PC PRE AMP BLK GX-R6
2-IC1A	EI-337228	IC M5218LO
2-IC4A	EI-336761	IC LA6458S
2-IC6A	EI-337228	IC M5218LO
2-IC11A	EI-349196	IC MA12058 (IC58)
2-IC11A	EI-336983	IC HA12038 (IC38)
2-IC12A	EI-348701	IC M51143L
2-TR1A to 3A	ET-328578	TR 2SC2320 E,F
2-TR5A	ET-307349	TR 2SD794 P,Q
2-TR6A	ET-328868	TR 2SD1012-V G,H
2-TR8A to 13A	ET-328578	TR 2SC2320 E,F
2-TR14A	ET-309353	TR 2SC2274K E,F
2-TR15A to 19A	ET-200505	TR 2SC2603 E,F
2-TR20A,21A	ET-309353	TR 2SC2274K E,F
2-TR24A,25A	ET-328578	TR 2SC2320 E,F
2-TR26A	ET-337258	TR 2SC1843 E,F
2-TR27A	ET-330607	TR 2SC1312S F,G
2-TR28A	ET-328578	TR 2SC2320 E,F
2-TR29A	ET-200505	TR 2SC2603 E,F
2-TR32A	ET-200505	TR 2SC2603 E,F
2-TR51A	ET-330607	TR 2SC1312S F,G
2-TR52A	ET-200505	TR 2SC2603 E,F
2-D1A	ED305704	D ZENER H HZ4 B2
2-D5A to 9A	ED-301911	D SILICON H DS448
2-D11A to 13A	ED-301911	D SILICON H DS448
2-D21A	ED-350800	D ZENER H 05Z4.7 Y,Z
2-D22A	ED-301911	D SILICON H DS448
2-VR1A	EV-342940	R S-FIX H H0811C344A 3P 203
2-VR2A	EV-345610	R S-FIX H H0811C307A 3P 102
2-VR3A	EV-345611	R S-FIX H H0811C343A 3P 502
2-VR4A	EV-342939	R S-FIX H H0811C313A 3P 103
2-VR5A,6A	EV-342942	R S-FIX H H0811C345A 3P 503
2-VR7A	EV-338467	R S-FIX H TM8K 3P 0.30W 104
2-RL1A	EQ-337067	RELAY LEAD LAB2NS 2NO 18V
2-T1A	EO-345836	COIL OSC 1 32-5008-12 100kHz
2-L1A	EO-337055	COIL VARI 1 FE002S 10MH
2-L1A	EO-669273	COIL FIX 2 FL5R200 180
2-FL1A,2A	EH-337695	FILTER DB 201AK-005 100kHz
2-FL4A	EO-315758	COIL TUN 1 100S-431 100.00KHZ
2-FL11A	EO-337044	COIL TUN 1 102AK-005
2-J1A	EJ-347664	PIN J YKC21-5053 P 4P
2-J2A	EJ-346076	DIN J TCS4690-01-1111 P 8P
2-FR3A	ER-318248	△ R FUSE ERD2FC S10 1/4W 47ROG
2-R4A	ER-326616	R OMF H SNP FS 1W 681J
2-C57A	EC-335306	C STY V F05 CQ09S 162J 250DC
2-C61A	EC-314992	C STY V F05 CQF09 681J 50DC
2-C69A	EC-310440	C STY V F05 CQF09 471J 50DC
2-C79A	EC-321482	C STY V F05 500 271J 50DC
2-C85A	EC-314992	C STY V F05 CQF09 681 50DC
2-J1B	EJ-345812	PHONE J HLJ0527-3714
2-J2B	EJ-344640	PHONE J HLJ4308-3034
2-VR1C	EV-337841	VR SLIDE 30P2SVOA B103

# COMPOSITION OF VARIOUS P.C BOARDS

## HX-R5 PRE AMP P.C BOARD T2045A5040A (HA12038)

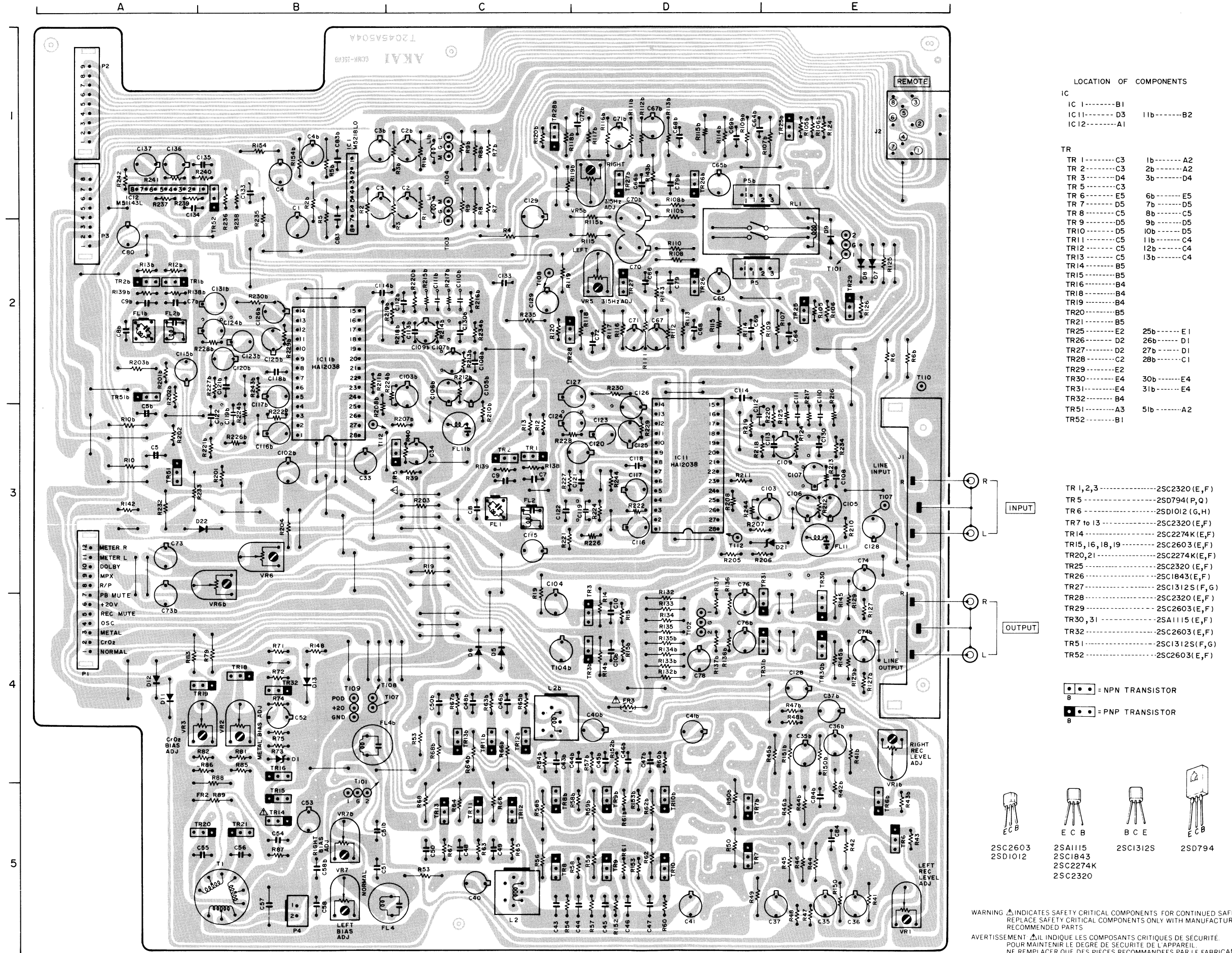

LOCATION OF COMPONENTS

IC 1-----B1  
 IC 11-----D3  
 IC 12-----A1

TR 1-----C3  
 TR 2-----C3  
 TR 3-----D4  
 TR 5-----C3  
 TR 6-----E5  
 TR 7-----D5  
 TR 8-----C5  
 TR 9-----D5  
 TR 10-----D5  
 TR 11-----C4  
 TR 12-----C5  
 TR 13-----C5  
 TR 14-----B5  
 TR 15-----B5  
 TR 16-----B4  
 TR 18-----B4  
 TR 19-----B4  
 TR 20-----B5  
 TR 21-----B5  
 TR 25-----E2  
 TR 26-----D2  
 TR 27-----D2  
 TR 28-----C1  
 TR 29-----E2  
 TR 30-----E2  
 TR 31-----E4  
 TR 32-----B4  
 TR 51-----A3  
 TR 52-----B1

TR 1, 2, 3 ----- 2SC2320 (E,F)  
 TR 5 ----- 2SD794 (P,Q)  
 TR 6 ----- 2SD1012 (G,H)  
 TR 7 to 13 ----- 2SC2320 (E,F)  
 TR 14 ----- 2SC2274K (E,F)  
 TR 15, 16, 18, 19 ----- 2SC2603 (E,F)  
 TR 20, 21 ----- 2SC2274K (E,F)  
 TR 25 ----- 2SC2320 (E,F)  
 TR 26 ----- 2SC1843 (E,F)  
 TR 27 ----- 2SC1312S (F,G)  
 TR 28 ----- 2SC2320 (E,F)  
 TR 29 ----- 2SC2603 (E,F)  
 TR 30, 31 ----- 2SA1115 (E,F)  
 TR 32 ----- 2SC2603 (E,F)  
 TR 51 ----- 2SC1312S (F,G)  
 TR 52 ----- 2SC2603 (E,F)

○ = NPN TRANSISTOR  
 □ = PNP TRANSISTOR

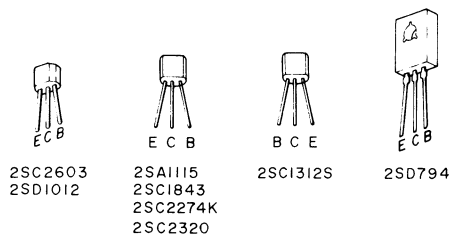

WARNING: Δ INDICATES SAFETY CRITICAL COMPONENTS. FOR CONTINUED SAFETY, REPLACE SAFETY CRITICAL COMPONENTS ONLY WITH MANUFACTURER'S RECOMMENDED PARTS.  
 AVERTISSEMENT: Δ IL INDIQUE LES COMPOSANTS CRITIQUES DE SECURITE. POUR MAINTENIR LE DEGRE DE SECURITE DE L'APPAREIL, NE REMPLACER QUE DES PIECES RECOMMANDEES PAR LE FABRICANT.

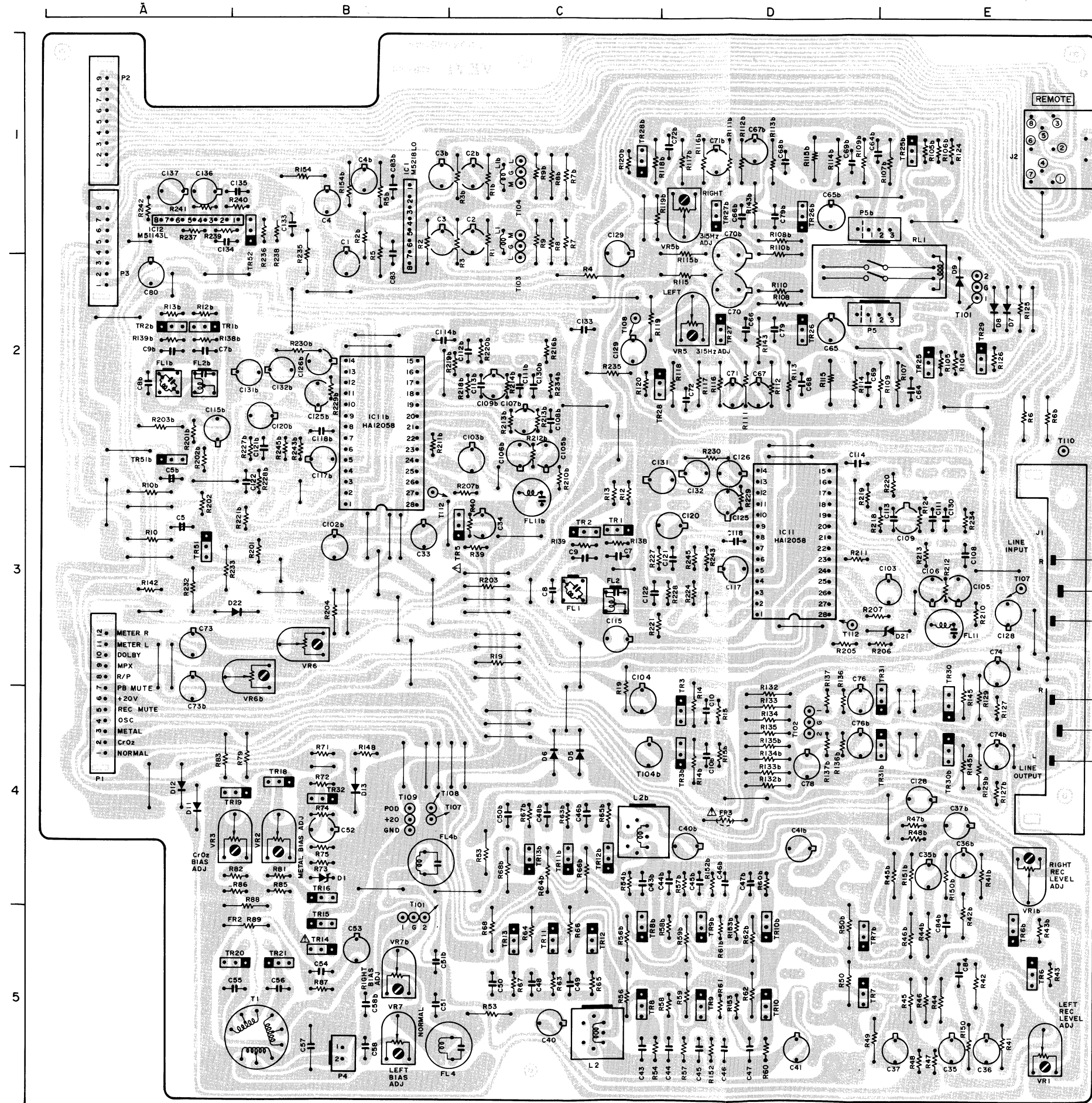

LOCATION OF COMPONENTS

- IC  
 IC 1-----B1  
 IC 11-----D3 11b-----B2  
 IC 12-----A1

- TR  
 TR 1-----C3 1b-----A2  
 TR 2-----C3 2b-----A2  
 TR 3-----D4 3b-----D4  
 TR 5-----C3  
 TR 6-----E5 6b-----E5  
 TR 7-----D5 7b-----D5  
 TR 8-----C5 8b-----C5  
 TR 9-----D5 9b-----D5  
 TR 10-----D5 10b-----D5  
 TR 11-----C5 11b-----C4  
 TR 12-----C5 12b-----C4  
 TR 13-----C5 13b-----C4  
 TR 14-----B5  
 TR 15-----B5  
 TR 16-----B4  
 TR 18-----B4  
 TR 19-----B4  
 TR 20-----B5  
 TR 21-----B5  
 TR 25-----E2 25b-----E1  
 TR 26-----D2 26b-----D1  
 TR 27-----D2 27b-----D1  
 TR 28-----C2 28b-----C1  
 TR 29-----E2  
 TR 30-----B3 30b-----E4  
 TR 31-----E4 31b-----E4  
 TR 32-----B4  
 TR 51-----A3 51b-----A2  
 TR 52-----B1

- TR 1, 2, 3 -----2SC2320 (E, F)  
 TR 5 -----2SD794 (P, Q)  
 TR 6 -----2SD1012 (G, H)  
 TR 7 to 13 -----2SC2320 (E, F)  
 TR 14 -----2SC2274K (E, F)  
 TR 15, 16, 18, 19 -----2SC2603 (E, F)  
 TR 20, 21 -----2SC2274K (E, F)  
 TR 25 -----2SC2320 (E, F)  
 TR 26 -----2SC1843 (E, F)  
 TR 27 -----2SC1312S (E, F, G)  
 TR 28 -----2SC2320 (E, F)  
 TR 29 -----2SC2603 (E, F)  
 TR 30, 31 -----2SA1115 (E, F)  
 TR 32 -----2SC2603 (E, F)  
 TR 51 -----2SC1312S (E, F, G)  
 TR 52 -----2SC2603 (E, F)

- = NPN TRANSISTOR  
 ••• = PNP TRANSISTOR

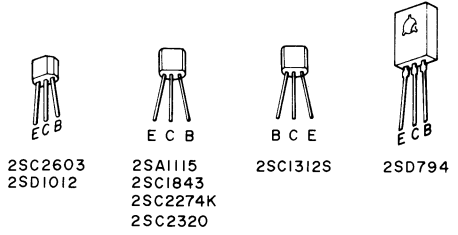

WARNING: ⚠ INDICATES SAFETY CRITICAL COMPONENTS. FOR CONTINUED SAFETY, REPLACE SAFETY CRITICAL COMPONENTS ONLY WITH MANUFACTURER'S RECOMMENDED PARTS.  
 AVERTISSEMENT: ⚠ IL INDIQUE LES COMPOSANTS CRITIQUES DE SÉCURITÉ. POUR MAINTENIR LE DEGRÉ DE SÉCURITÉ DE L'APPAREIL, NE REMPLACER QUE DES PIÈCES RECOMMANDÉES PAR LE FABRICANT.

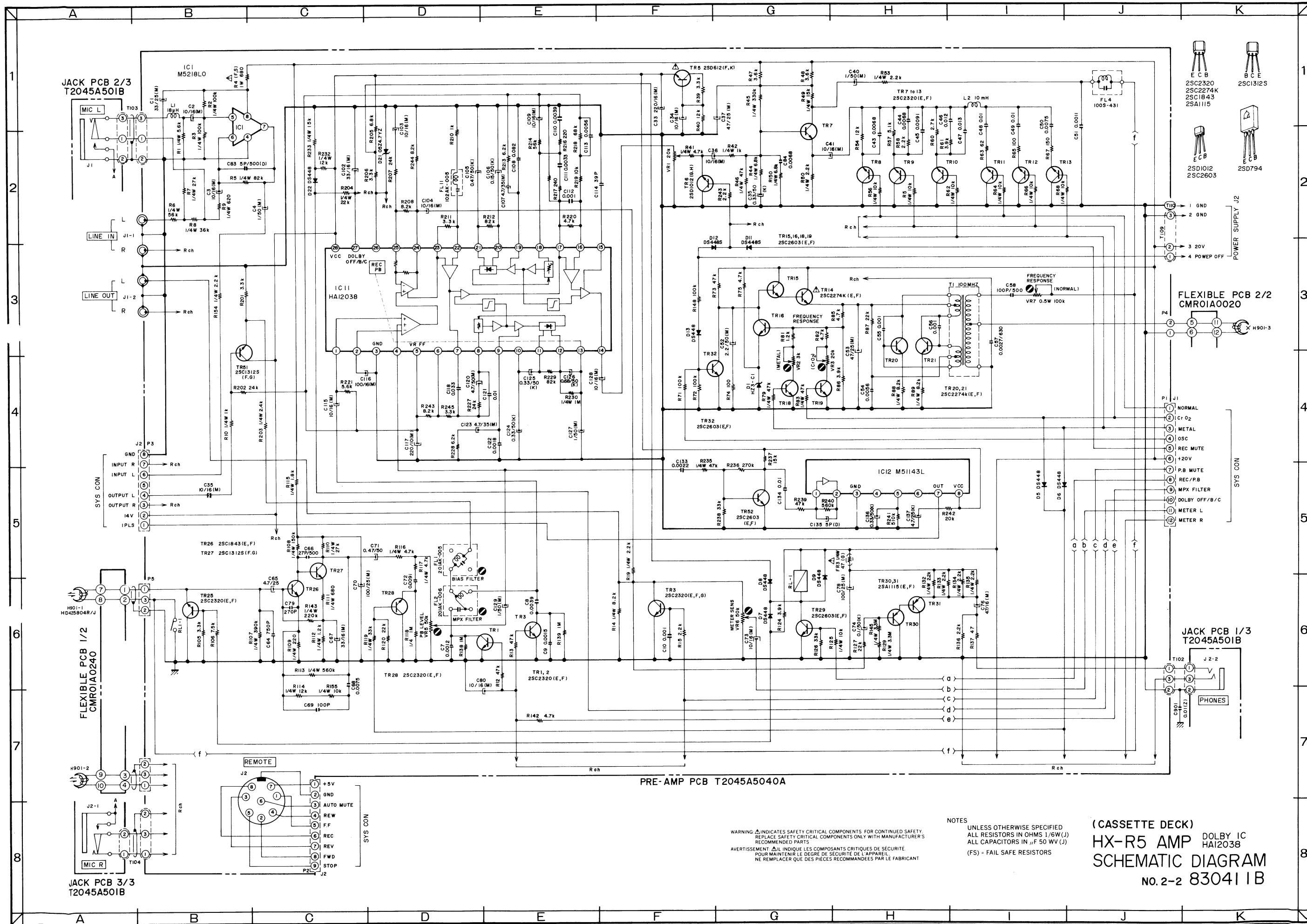

WARNING:  $\Delta$  INDICATES SAFETY CRITICAL COMPONENTS. FOR CONTINUED SAFETY, REPLACE SAFETY CRITICAL COMPONENTS ONLY WITH MANUFACTURER'S RECOMMENDED PARTS.  
 AVERTISSEMENT:  $\Delta$  IL INDIQUE LES COMPOSANTS CRITIQUES DE SÉCURITÉ. NE REMPLACER QUE DES PIÈCES RECOMMANDÉES PAR LE FABRICANT.

NOTES  
 UNLESS OTHERWISE SPECIFIED ALL RESISTORS IN OHMS 1/6W (J) ALL CAPACITORS IN  $\mu$ F 50 WV (J) (FS) = FAIL SAFE RESISTORS

(CASSETTE DECK)  
**HX-R5 AMP** DOLBY IC  
 HAI2038  
**SCHEMATIC DIAGRAM**  
 No. 2-2 830411B

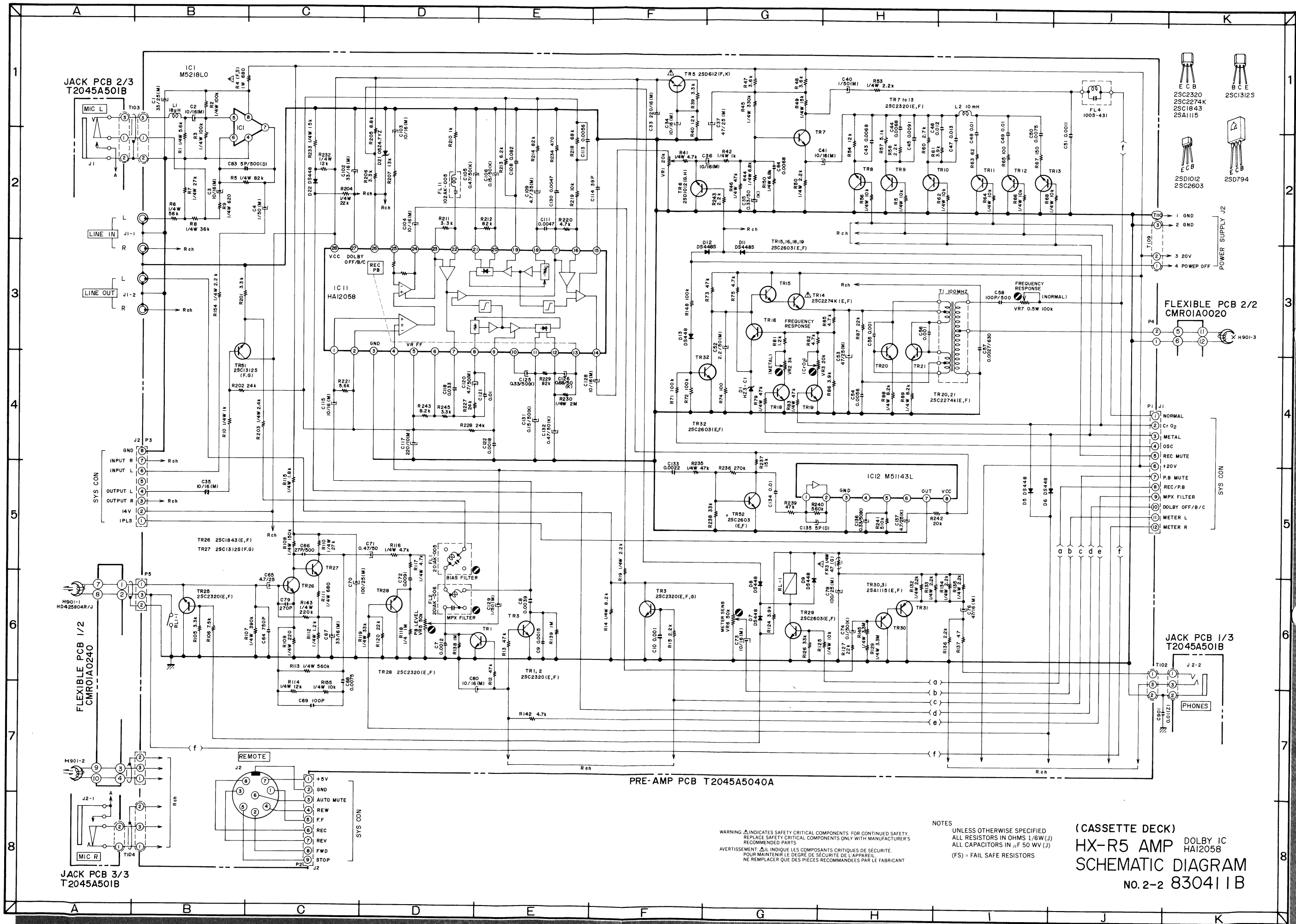

WARNING: Δ INDICATES SAFETY CRITICAL COMPONENTS. FOR CONTINUED SAFETY, REPLACE SAFETY CRITICAL COMPONENTS ONLY WITH MANUFACTURER'S RECOMMENDED PARTS.  
 AVERTISSEMENT: Δ IL INDIQUE LES COMPOSANTS CRITIQUES DE SÉCURITÉ. POUR MAINTENIR LE DEGRÉ DE SÉCURITÉ DE L'APPAREIL, NE REMPLACEZ QUE DES PIÈCES RECOMMANDÉES PAR LE FABRICANT.

NOTES  
 UNLESS OTHERWISE SPECIFIED  
 ALL RESISTORS IN OHMS 1/6W(J)  
 ALL CAPACITORS IN μF 50 WV(J)  
 (FS) = FAIL SAFE RESISTORS

(CASSETTE DECK)  
**HX-R5 AMP** DOLBY IC  
**HA12058**  
**SCHEMATIC DIAGRAM**  
 NO. 2-2 830411B



# COMPOSITION OF VARIOUS P.C BOARDS

## GX-R6 PRE AMP P.C BOARD T2045A5040 (HA12038)



### LOCATION OF COMPONENTS

IC	
IC 1	B1
IC 4	E5
IC 6	E4
IC11	D3
IC12	A1

TR	
TR 1	C3
TR 2	C3
TR 3	D4
TR 5	C3
TR 6	E5
TR 8	C5
TR 9	D5
TR10	D5
TR11	C5
TR12	C5
TR13	C5
TR14	B5
TR15	B5
TR16	B4
TR18	B4
TR19	B4
TR20	B5
TR21	B5
TR24	E2
TR25	E2
TR26	D2
TR27	D2
TR28	C2
TR29	E2
TR32	B4
TR51	A2
TR52	A1

11b	
11b	B2

1b	
1b	A2
2b	A2
3b	D4
6b	E5
3b	C5
9b	D5
10b	D5
11b	C4
12b	C4
3b	C4

24b	
24b	E1
25b	E1
26b	D1
27b	D1
28b	C1

OUTPUT	
TR 1, 2, 3	2SC2320 (E,F)
TR 5	2SD794 (P,Q)
TR 6	2SD1012-V(G,H)
TR 8 to 13	2SC2320 (E,F)
TR14	2SC2274K (E,F)
TR15, 16, 18, 19	2SC2603 (E,F)
TR20, 21	2SC2274K (E,F)
TR24, 25	2SC2320 (E,F)
TR26	2SC1843 (E,F)
TR27	2SC1312S (F,G)
TR28	2SC2320 (E,F)
TR29, 32	2SC2603 (E,F)
TR51	2SC1312S (F,G)
TR52	2SC2603 (E,F)

= NPN TRANSISTOR  
 = PNP TRANSISTOR

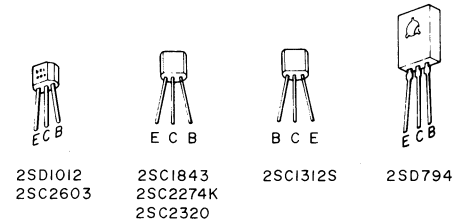

WARNING: INDICATES SAFETY CRITICAL COMPONENTS FOR CONTINUED SAFETY. REPLACE SAFETY CRITICAL COMPONENTS ONLY WITH MANUFACTURER'S RECOMMENDED PARTS.  
 AVERTISSEMENT: IL INDIQUE LES COMPOSANTS CRITIQUES DE SÉCURITÉ. POUR MAINTENIR LE DEGRÉ DE SÉCURITÉ DE L'APPAREIL, NE REMPLACER QUE DES PIÈCES RECOMMANDÉES PAR LE FABRICANT.





